

**MOVING / COMPACTING
FEEDING / CONVEY
SEPARTING / SELECTION**



Air Hammer & Pneumatic Vibrator

APPLICATION

INTRODUCTION

In automatic factories, there are different piping systems, conveyors, weighing arrangements, life testing equipments, and dust collectors for production process.

Material characteristic (moisture, S.G., size..) and equipment design (shape, layout...) are usually the causes of medium accumulation in the pipes and tanks.

By applying pneumatic vibrators in the problem area, it will provide the best solution. Pneumatic vibrators will shake off the clogged or attached material and eliminate friction during automatic production.

WORKING PRINCIPLE

Vibration is created by the high centrifugal force of the circulating steel roller, which runs on a steel ring at very high frequency.

MERIT OF VIBRATORS

The body of pneumatic vibrator is made of strengthened aluminum alloy. It is simple structured small size vibrator with strong vibrating force. The vibrator is responsive for sudden activation / deactivation, which eliminates the damage of the equipments to the minimum level.

The vibrator is forced by compressed air. It is easily operated without spark. The working principle does not cause sparks, which can be applied in hazardous, humid or other severe environment. Power force, frequency and amplitude can be adjusted while operating.

MODERATE TYPE

Application \ Model	Air Hammer	Piston Vibrator		Pneumatic Vibrator		
	BAH	BVP□□ S Strike	BVP□□ C Cushion	BVK BALL	BVR ROLLER	BVT TURBINE
Get Rid of Blockage	EXCELLENT	EXCELLENT	EXCELLENT	EXCELLENT	EXCELLENT	EXCELLENT
Pipe Accumulation	EXCELLENT	EXCELLENT	EXCELLENT	EXCELLENT	EXCELLENT	EXCELLENT
Derust Piping	EXCELLENT	EXCELLENT	EXCELLENT	FAIR	FAIR	EXCELLENT
Vibrating Delivery Sieving	EXCELLENT	EXCELLENT	EXCELLENT	EXCELLENT	EXCELLENT	EXCELLENT
Arrangement & Conveyance	EXCELLENT	EXCELLENT	EXCELLENT	EXCELLENT	EXCELLENT	EXCELLENT
Filling & Packing	EXCELLENT	EXCELLENT	EXCELLENT	EXCELLENT	EXCELLENT	EXCELLENT
Defoaming While Filling	EXCELLENT	EXCELLENT	EXCELLENT	EXCELLENT	EXCELLENT	EXCELLENT
Concrete Injection	EXCELLENT	EXCELLENT	EXCELLENT	EXCELLENT	EXCELLENT	EXCELLENT
Sand Compacted While Molding	EXCELLENT	EXCELLENT	EXCELLENT	EXCELLENT	EXCELLENT	FAIR
Static Electricity Coating	EXCELLENT	EXCELLENT	EXCELLENT	EXCELLENT	EXCELLENT	EXCELLENT
Life Testing	EXCELLENT	EXCELLENT	EXCELLENT	EXCELLENT	EXCELLENT	EXCELLENT

 EXCELLENT
  FAIR

BVP SERIES PISTON VIBRATOR (AIR CUSHIONED MODEL)

FEATURES

1. Highly strengthened aluminum body.
2. Low frequency vibration is the best solution to Bridge-break.
3. Frequency and amplitude of vibration can be adjusted as required.
4. Sudden activation and deactivation.

Air cushioned type, low noise character. It is a good solution to shake off attachment on the tank wall and for application that requires quietness. Also, it can be designed to apply on vibrating separator, and conveyer.

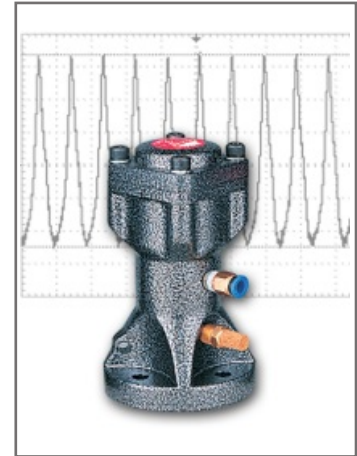

Temperature: -40~100°C
Noise level range: 80-115 dBA

WORKING PRINCIPLE

There are tubes located in both end of cylinder. Air is compressed into the tube to push piston from one side to the other side. Vibration power is arose by the back and forth movement of piston in the body. Air cushion at both ends will keep piston away from striking onto the body. Hence, the piston will not produce noise.

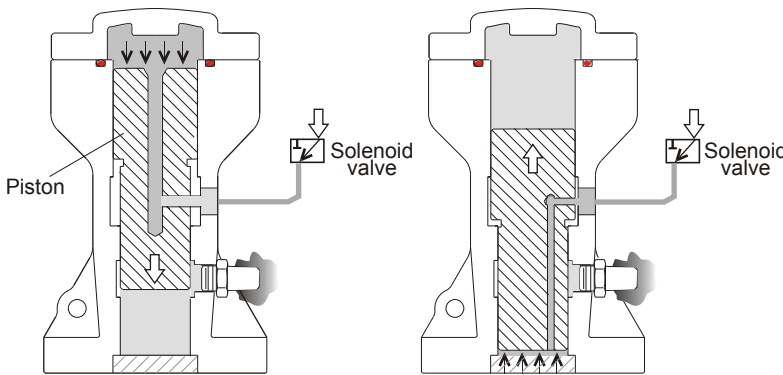

(1) Air is compressed into the body to push piston move downward. Air in the bottom side will be exhausted by the outlet hole.

(2) Compressed air will push the piston back from the bottom. The movement repeats.

Model No.	A	ϕB	ϕC	D	ϕH	IN	OUT
BVP-30C	138	80	60	12	9	1/8" PF	1/8" PF
BVP-40C	166	100	75	16	11	1/4" PF	1/4" PF
BVP-60C	208	140	105	16	15	1/4" PF	1/4" PF

Unit= mm

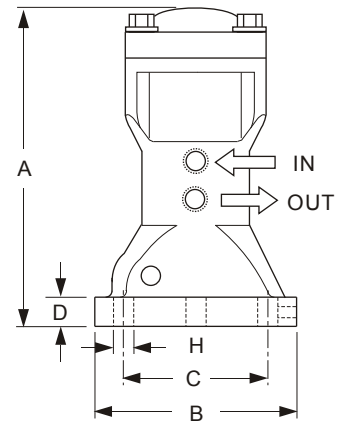

Model No.	FREQUENCY (V.P.M.)			FORCE (N)			AIR CONSUMPTION (ℓ / min)	WEIGHT (g)
	2kg/cm ²	4kg/cm ²	6kg/cm ²	2kg/cm ²	4kg/cm ²	6kg/cm ²		
BVP-30C	1765	2308	2857	195	380	560	230	0.9 kg
BVP-40C	1333	1677	1875	275	531	715	249	1.9 kg
BVP-60C	1000	1200	1340	404	780	1030	269	4.5 kg

BVP SERIES PISTON VIBRATOR (IMPACT MODEL)

FEATURES

1. Highly strengthened aluminum body.
2. Low frequency/ continuous impact model, sudden activation/ deactivation.
3. Frequency and amplitude of impact can be adjusted as required.
4. Direct impact onto target object to produce the optimum vibration feedback.

Direct impact of piston impact type can get rid of rust and material attachment inside the pipes, and low S.G, high moisture material, and material built-up in the tank.

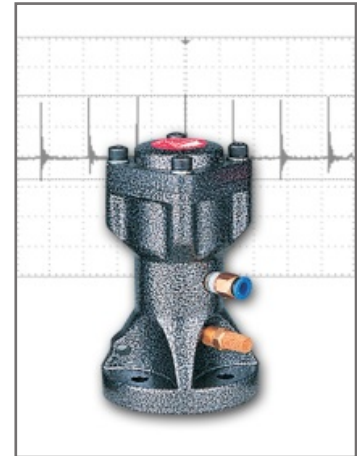

Temperature: -40~100°C
Noise level range: 80-115 dBA

WORKING PRINCIPLE

There are air-breathing tubes located in both end side of cylinder. Air will be compressed in to push piston from one side to the other side. Vibration is arose by the back and forth movement of the piston in the body. Air cushion at top end will keep piston away from striking onto the body. On the other hand, piston will strike directly on the bottom of the body to produce strong impact.

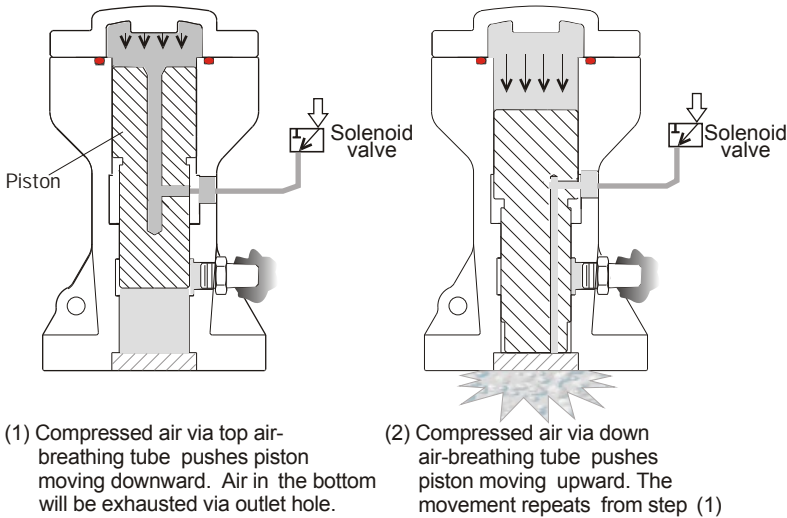

Model No.	A	ϕB	ϕC	D	ϕH	IN	OUT
BVP-30S	138	80	60	12	9	1/8" PF	1/8" PF
BVP-40S	166	100	75	16	11	1/4" PF	1/4" PF
BVP-60S	208	140	105	16	15	1/4" PF	1/4" PF

單位= mm

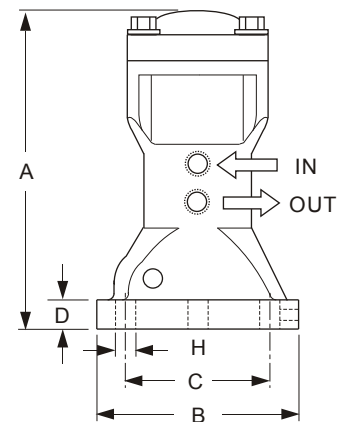

Model No.	FREQUENCY (V.P.M.)			FORCE (N)			AIR CONSUMPTION (ℓ / min)	WEIGHT (g)
	2kg/cm ²	4kg/cm ²	6kg/cm ²	2kg/cm ²	4kg/cm ²	6kg/cm ²		
BVP-30S	1900	2800	3500	3600	5400	6200	250	1.0 kg
BVP-40S	1700	2400	3000	6450	8750	9400	270	2.1 kg
BVP-60S	1200	1800	1900	6900	12850	13850	300	4.8 kg

BAH SERIES SINGLE IMPACTING TYPE

FEATURES

1. One impact wave per one shot.
2. Highly strengthened aluminum structure.
3. Impact force and interval timing can be set by request.
4. Extended magnetic strength to increase piston impact power.

The single impact model of Air Hammer imparts on one specific target spot on limited target.
 Air Hammer impact will not separate water out of humid mixtures.
 It is often applied onto pipe or elbow clean and tank filled with humidity or small S.G. Material.



Temperature: -40~100°C
 Noise level range: 80-115 dBA

WORKING PRINCIPLE

There is a powerful magnet inside the air hammer. As the inlet air pressure is higher than magnetic force, the hammer and magnet will separate and cause strong impact power. Spring will bring hammer back to the initial position automatically after the impact.

By doing so, the air pressure will be released and the strength of air pressure will be delivered to target impact container. It will help to smooth the flow and prevent accumulation inside the container.

(1) The hammer is tightly attached to magnetic anchor plate when air pressure is smaller than magnetic power.

(2) The hammer instantly drops down when air pressure overcomes the strength of Magnet to cause a downward impact.

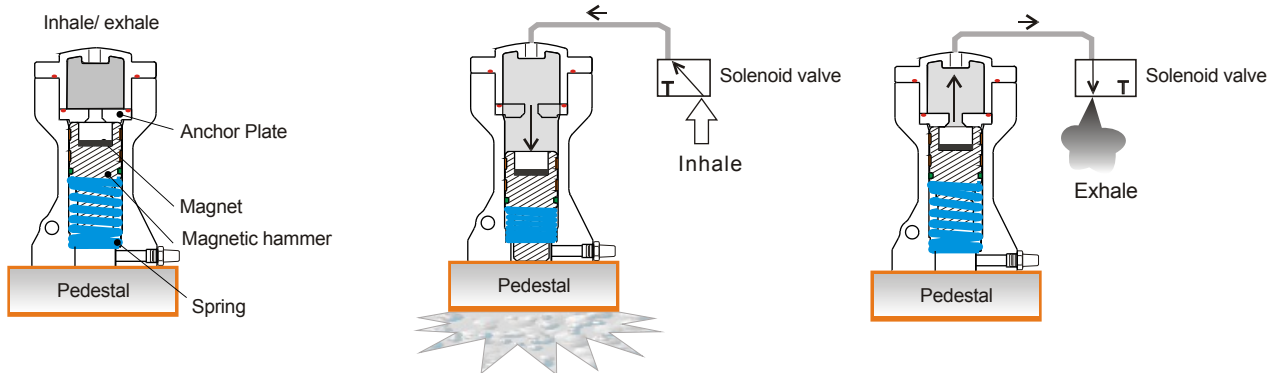

Unit= mm

Model No.	A	φB	φC	D	φH	IN	OUT
BAH-30	138	80	60	12	9	1/4" PT	1/8" PT
BAH-40	166	100	75	16	11	1/4" PT	1/8" PT
BAH-60	208	140	105	16	15	1/4" PT	1/8" PT
BAH-80	269	172	140	24	19	3/8" PT	1/4" PT

Model No.	USEFUL PRESSURE	FORCE	AIR CONSUMPTION	WEIGHT (g)
BAH-30	3~6 kg/cm ²	1.0 kg.m/s	0.028 l/e.t.	1.1kg
BAH-40	3~6 kg/cm ²	2.8 kg.m/s	0.082 l/e.t.	1.8kg
BAH-60	4~7 kg/cm ²	7.4 kg.m/s	0.228 l/e.t.	4.0kg
BAH-80	4~7 kg/cm ²	12.5 kg.m/s	0.455 l/e.t.	8.4kg

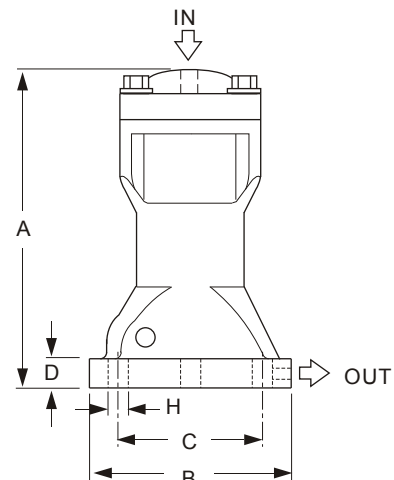

BVK SERIES PNEUMATIC BALL VIBRATOR

FEATURES

1. Special aluminum alloy, small size, light weight.
2. Fine enclosure protection can be applied in high humidity or dusty working area.
3. Frequency and amplitude of vibration can be adjusted as required.
4. Low price and durable.

The best choice for bridge-break in thin wall, small tank. This model can be used in vibrating separator, vibrating conveyor, automatic component arrangement, electroplating built-up, protection material packing process, process molding.

WORKING PRINCIPLE

Pneumatic Ball vibrator is equipped with steel ring and ball inside. It is tightly sealed by plastic side covers. Vibration takes place when internal ball is pushed by compressed air and centrifugal force is produced by ball rotary motion.

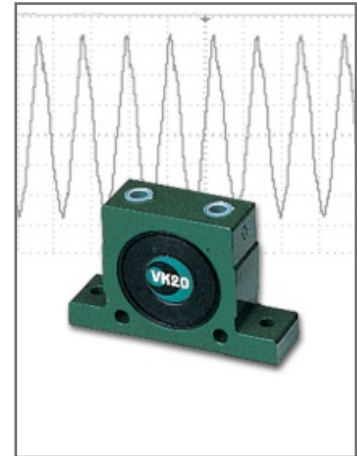

Temperature: -40~100°C
Noise level range: 75-95 dBA

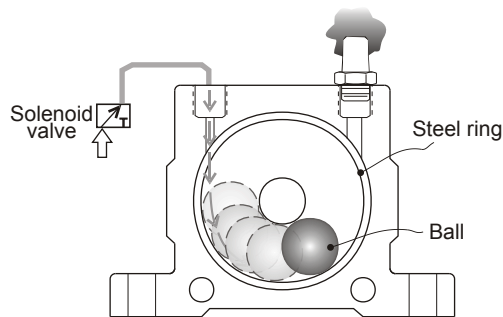

Unit= mm

Model No.	A	B	C	D	E	H	IN	OUT
BVK-10	51	86	68	12	20	φ7	1/4"PF	1/4"PF
BVK-13	67	113	90	16	24	φ9	1/4"PF	1/4"PF
BVK-16					27			
BVK-20	83	128	104	16	33	φ9	1/4"PF	1/4"PF
BVK-25					38			
BVK-32	103	160	130	20	44	φ11	3/8"PF	3/8"PF

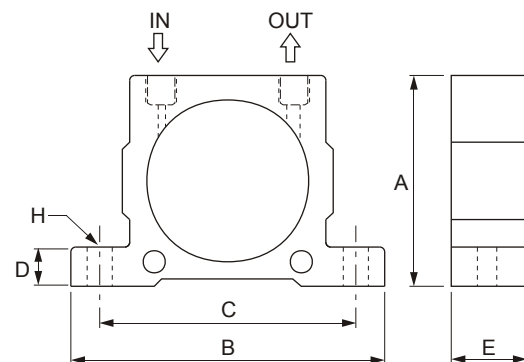

Model No.	FREQUENCY (V.P.M.)			FORCE (N)			AIR CONSUMPTION (ℓ / min)			WEIGHT (g)
	2Bar 29PSI	4Bar 58PSI	6Bar 87PSI	2Bar 29PSI	4Bar 58PSI	6Bar 87PSI	2Bar 29PSI	4Bar 58PSI	6Bar 87PSI	
BVK-10	22,500	28,000	34,000	250	470	710	92	150	200	140
BVK-13	15,000	18,500	22,500	320	550	870	94	158	225	260
BVK-16	13,000	17,000	19,500	450	800	1,100	122	200	280	300
BVK-20	10,500	14,500	16,500	720	1,220	1,720	130	230	340	530
BVK-25	9,200	12,200	14,000	930	1,570	2,050	160	290	425	630
BVK-32	7,800	9,700	12,500	1,510	2,470	3,210	215	375	570	1150

BVR SERIES PNEUMATIC ROLLER VIBRATOR

FEATURES

1. Special aluminum body, small size, light weight
2. Frequency and amplitude of vibration can be adjusted as required
3. The strongest vibration force drove by roller among other same size products

Its high vibration frequency can prevent material jam in pipe delivery, it can also be applied in bridge-break, concrete injection operation process.

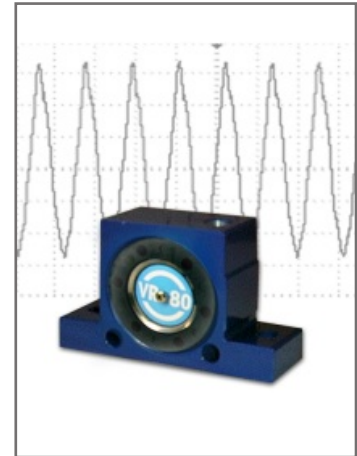

Temperature: -40~100°C
Noise level range: 75-100 dBA

WORKING PRINCIPLE

Pneumatic roller vibrator is structured with roller and ring with multi nozzles. It is tightly sealed by plastic side covers. Vibration takes place when roller is pushed by compressed air and centrifugal force is produced by ball rotary motion.

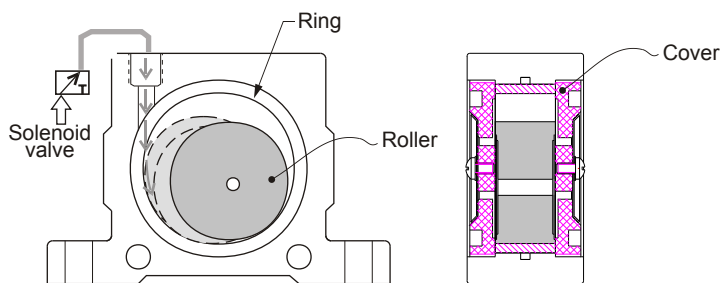

UNIT= mm

Model No.	A	B	C	D	E	H	IN
BVR-50	51	86	68	12	29	φ7	1/8"PF
BVR-65	67	113	90	16	37	φ9	1/4"PF
BVR-80	83	128	104	16	42.5	φ9	1/4"PF
BVR-100	103	160	130	20	52	φ11	3/8"PF

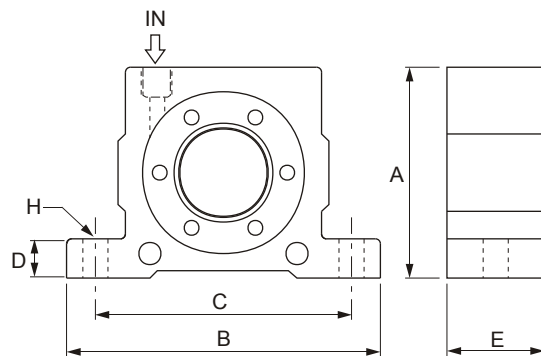

Model No.	FREQUENCY (V.P.M.)			FORCE (N)			AIR CONSUMPTION (ℓ / min)			WEIGHT (g)
	2Bar 29PSI	4Bar 58PSI	6Bar 87PSI	2Bar 29PSI	4Bar 58PSI	6Bar 87PSI	2Bar 29PSI	4Bar 58PSI	6Bar 87PSI	
BVR-50	25,000	35,000	36,000	1,070	2,920	4,220	100	145	195	240
BVR-65	19,000	21,000	26,000	2,730	4,830	6,120	200	300	400	540
BVR-80	15,500	18,500	19,000	3,000	6,090	7,450	290	430	570	950
BVR-100	11,000	14,000	16,000	3,750	6,750	8,900	370	550	730	1800

BVT SERIES PNEUMATIC TURBINE VIBRATOR

FEATURES

1. Special Aluminum body, low noise, high vibration frequency , small size and light weight.
2. Sudden activation/ deactivation
3. Frequency and amplitude of vibration can be adjusted as required

Best choice in low noise environment. It is usually installed on vibrating separator, conveyer, automatic arrangement machine, packing machine, filling machine etc.



Temperature: -40~100°C
Noise level range: 60-75 dBA

WORKING PRINCIPLE

The vibration is produced by centrifugal force of the unbalance weights from turbine movement. The operation noise is low because the ball bearing supports turbine running.

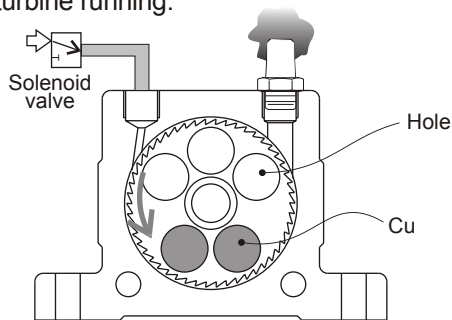

單位 = mm

Model No.	A	B	C	D	E	H	R
BVT-08	51	86	68	12	33	φ7	1/8"PF
BVT-10							
BVT-13	67	113	90	16	42	φ9	1/4"PF
BVT-16							
BVT-20	83	128	104	16	56	φ9	1/4"PF
BVT-25							
BVT-30	100	160	130	20	73	φ11	3/8"PF
BVT-36							

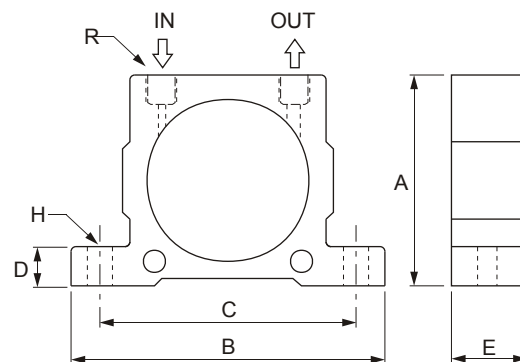

Model No.	FREQUENCY (V.P.M.)			FORCE (N)			AIR CONSUMPTION (ℓ / min)			WEIGHT (g)
	2Bar 29PSI	4Bar 58PSI	6Bar 87PSI	2Bar 29PSI	4Bar 58PSI	6Bar 87PSI	2Bar 29PSI	4Bar 58PSI	6Bar 87PSI	
BVT-08	36,000	42,000	46,000	990	2,060	2,910	46	80	112	250
BVT-10	27,500	35,000	37,500	840	1,390	2,400	46	80	112	255
BVT-13	26,000	30,000	33,000	1,400	2,440	3,730	120	200	290	565
BVT-16	17,000	21,500	24,000	1,220	2,090	3,160	120	200	290	580
BVT-20	17,000	20,000	23,000	2,170	4,040	5,520	185	325	455	1090
BVT-25	12,000	15,500	17,000	2,120	3,510	5,070	185	325	455	1120
BVT-30	13,000	14,000	16,000	3,380	5,430	7,540	330	530	745	2200
BVT-36	8,000	10,000	13,000	3,290	5,360	7,190	330	530	745	2300

ACCUMULATED MATERIAL SOLUTION

Different applications require various tanks. Customers choose appropriate vibrators to meet application demand (tank shape/ material, applied material humidity/ S.G./ granule size ...). Suitable vibrator will not only prevent obstruction problem but also avoid the damage of tank wall.

Big amplitude, low frequency piston types are suitable in granule with small S.G. . AB1/AB2/AB3 types are better choices for high S.G. or material accumulation in filtration environment. It is recommended to use multiple vibrators in serious clogging situation or big tank surrounding.

Accumulation condition and vibrator installation

According to various clogging situations, the recommended vibrators and suitable installation positions (usually 1/2L or 1/3L) are shown by below.

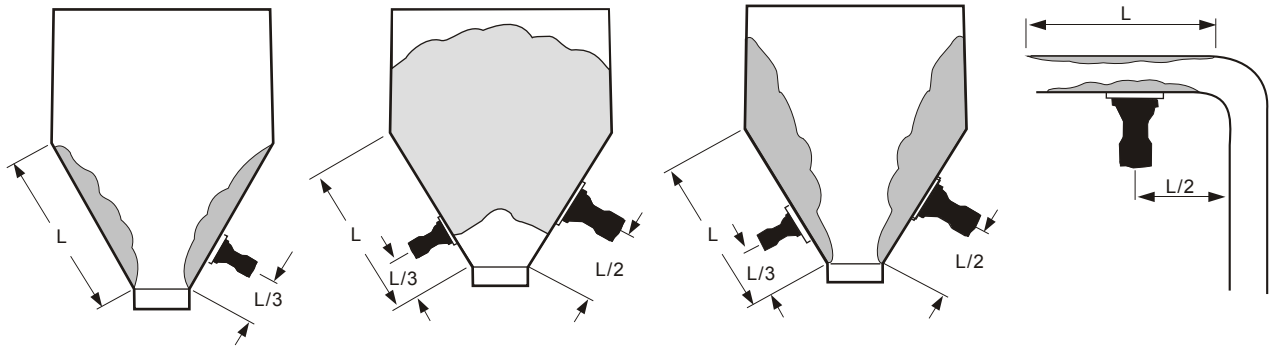

Vibration force calculation

Taking accumulation situation into consideration, appropriate vibrator will give 0.2~0.4 G accelerated vibration force onto target object.

$$F=0.2\sim 0.4GW,$$

F: Vibration force (N)
 G: 9.8m/s²
 W: Material weight (KG)

EX: Cone tank, R=3.5M, r=2.5M, Tank height H=2M, material S.G.=0.8, please calculate the vibration needed for this tank.

Sol: Get volume of material first (please refer to fig. on the right for formula) .
 Material Weight (W)=volume(V)*specific gravity(S.G)
 Vibration F=0.2 GW (G=9.8m/S², W=material weight)

Material weight calculation

Cone volume $V= 3.14 \times \frac{2}{3} (3.5 \times 3.5 + 3.5 \times 0.5 + 0.25 \times 0.5) = 29.83 (m^3)$
 Material Weight $W= 29.83 \times 0.8 = 23.86 = 23680 (kg)$
 Vibration $F= 0.2 \times 23680 \times 9.8 = 46765$ Newton Force(N)

W: Material weight (KG)
 V: Chute volume (M³)
 γ: Specific gravity

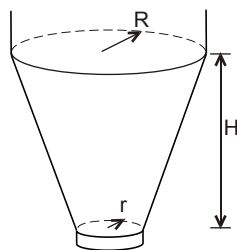

$$W=1000V\gamma \quad V= \frac{\pi H}{3} (R^2+Rr+r^2)$$

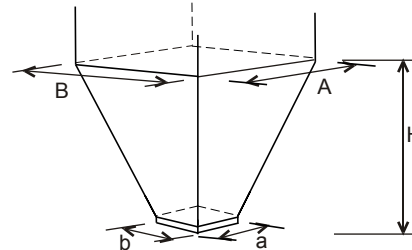

$$V= \frac{H}{6} [A \times B + (A+a)(B+b) + a \times b]$$

INSTALLATION

Vibration force transmits more efficiently in conical hopper tank than in rectangular hopper. It is recommended to install two vibrators for rectangular hopper application.

1. Vibration force can be transmitted more efficiently by using U shape steel supporter. It can help material fall smoothly in the tank or pipe. It also reduces tank damage.
2. U shape steel or fixer can prevent irregular movement of vibrators. To avoid possible damage on the tank wall caused by vibration force, stitch weld method is suggested. (10mm space will be required on two ends of U shape steel)
3. Reinforced board is required between U shape steel and thin tank wall.
4. Cross installed of U shape steel can increase vibration field in big hopper tank.

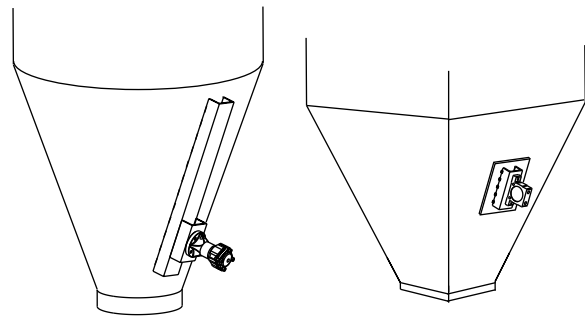
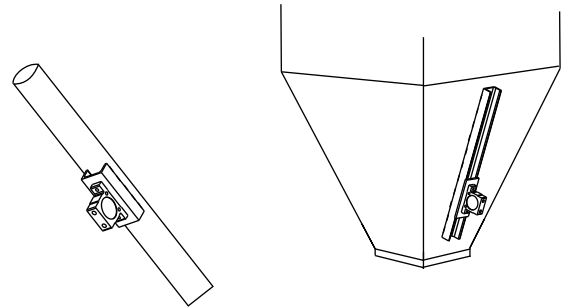

ATTENTION

Vibrator has to be fixed by high tension bolt, washer, and spring washer. It is suggested to use security cable if vibrator is installed onto hopper.

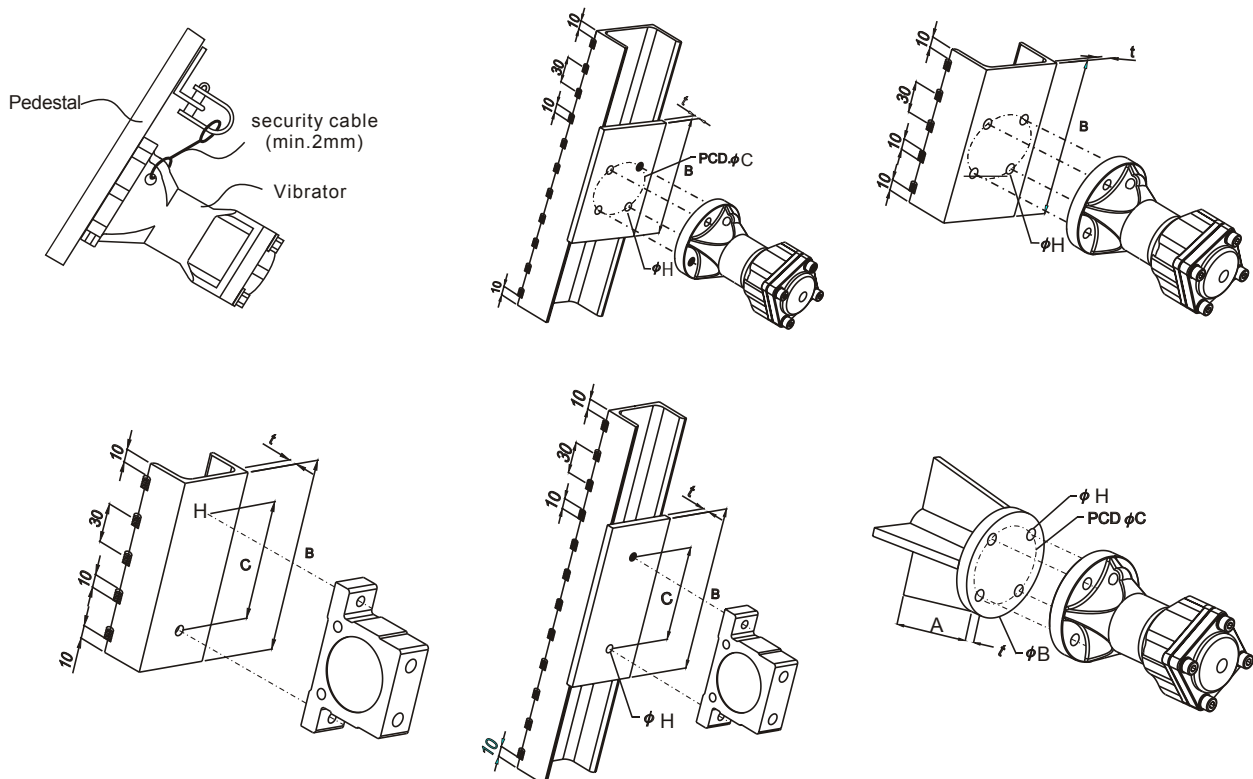

AE510 CONTROL BOX FOR AIR CONSUMED VIBRATOR

It is designed specially for application of various bridge break equipments. Application: Control by one CPU; users could enter program from the keypad according to their requirement. It can control 8 pcs of vibrators with 21 operating modes. Besides vibrator on the catalogue, it can also work with vibrating motor or air blaster.

ATTENTION

Material outlet must be opened when vibrator is in operation. It is recommended to share the power supply for control device and vibrator control box so both can work synchronously.

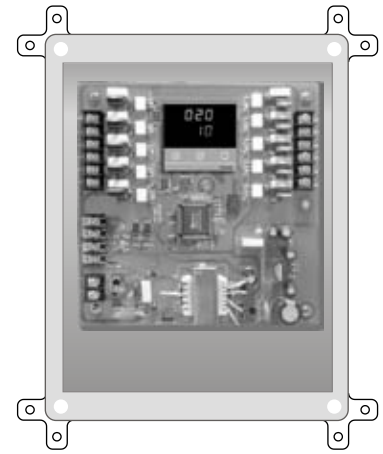

WORKING PRINCIPLE

- Users could set 1~8 vibrators' operating modes by themselves
- Impact time (T2): 1 second~ 60 minutes can be set
- Working time (T3): 1~5 impact frequency within T3 can be set
- Interval (T4): 1 second~ 60 minutes can be set
- Cycle time (T5): 1 minute~ 24 hours can be set
- Rest time : 1 minute~ 24 hours, Time counted during rest time, shown on LED display.

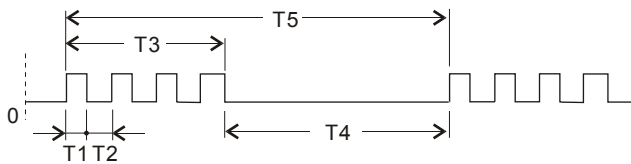

- Error indicator will be shown when wrong working time occurs
- Operating modes:

A. (8 ON)

Octal output sequential function: Sequential impact order, it returns to the first vibrator impact automatically after that of eighth.

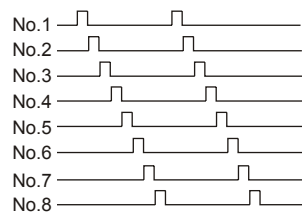

Octal output singlegroup sequential function

B. (6 ON / 2 OFF)

Dual output in triple groups sequential function: Sequential impact order, it returns to the first group impact automatically after that of third.

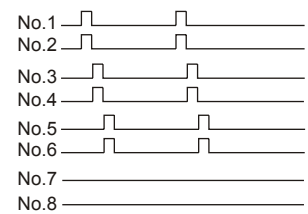

Dual output intriple group sequential function

C. (4 ON / 4 OFF)

Quad output in single group sequential function: Three impacts for each vibrator within working time

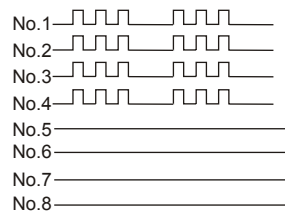

Quad output insingle groups sequential function

D. (4 ON)

Four vibrators work. Sequential impact order. Three impacts for one vibrator within working time, it returns to the first vibrator impact automatically after that of fourth.

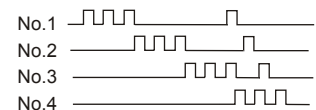

quad 3 impacts sequential function

Specification:

Enclosure protection:

Engineering plastic

IP65 or IEC529

Ambient temperature:-10~60°C

Supply voltage:

110V / 220Vac 50/60Hz

Relay output: 8xSPDT

Contact Rating: 7A/250VAC

Key pad: 4 Key Pad

Display: LEDx4

Fuse: 1A

Consumption power: 3W

AE610/620 Programmable Vibrating Controller



Application and features

Air hammer is required to solve block problem in some process of storage, conveyance, air dusting system to facilitate production. The most effective way is by jetting vibrator which applies to conveyor machinery, sifting machinery, chilling machinery, vibrating expectancy tester and packaging machinery. It is cost-effective solution in process automation.

AE610/620 is designed to offer various working modes which are CNC-controlled to offer 1-10/20 output control. User may select the best work mode based on equipment and material nature.

Spec.

- Power: 100~240Vac \pm 10% ,50Hz/60Hz
- Ambient temp: -20~60°C
- Output type: silicon controlled rectifier
- Output rating: 200VA/ 1.2A
- EMC test: compliant with IEC60947
- Mechanical stress test: compliant with IEC60068
- Vibration stress test: compliant with IEC60529
- EMC test compliant with IEC61000

IEC60092

IEC60068

Operation interface description

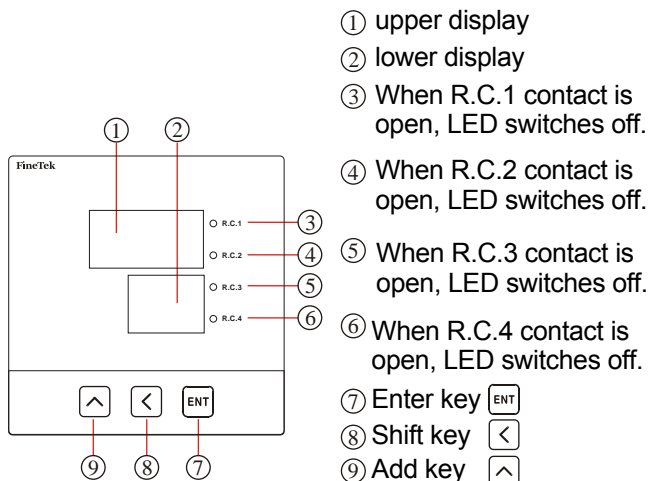

Dimension

*AE610/ 620

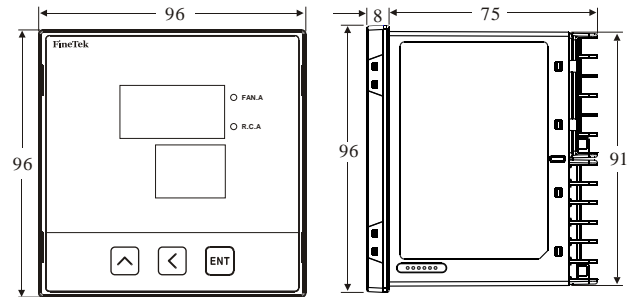

Opening dimension

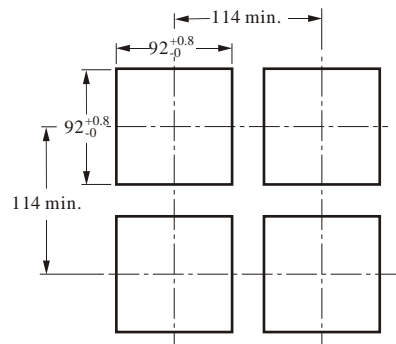

Contact Description

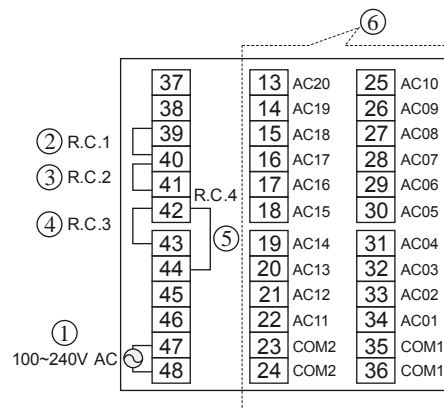

- ① Power terminal: terminal 47, 48
- ② First set of protective terminals for inlet: (R.C.1) The control of inlet equipment is connected with terminal 39, 40.
- ③ First set of protective terminals for inlet: (R.C.2) The control of inlet equipment is connected with terminal 40, 41.
- ④ First set of protective terminals for inlet: (R.C.3) The control of inlet equipment is connected with terminal 42, 43.
- ⑤ First set of protective terminals for inlet: (R.C.4) The control of inlet equipment is connected with terminal 42, 44.
- ⑥ Output terminal: Terminals connect to COM1 and COM2 as mutual contact valve.

AIR SUPPLY AND LUBRICATION

AIR SUPPLY

The moisture in the compressed air will erode pipes and accessories, then weaken the vibrator's performance. Make sure necessary steps are followed before applying. To fully utilize vibrator performance, choose appropriate product for different application.

LUBRICATION

All vibrators require lubricating oil to smooth the operation. Low viscosity oil will be injected into cup of F.R.L. combination unit to adjust required spread oil amount. To aim at specific application requirement, muffler can be applied onto exhaust tube in outside area to prevent food from pollution. Or to inject 2~3 drops of edible oil via air inlet sometimes is an alternative choice. AA2 series don't need lubrication unless they are running frequently.

TUBING ARRANGEMENT

Muffler can reduce noise and prevent dust enter the vibrator. The size of tubing should meet with that of vibration air inlet/ exhaust. In the meantime, as two vibrators work simultaneously, length of tubing should be equal after separation. In the meantime, the cross section of tubing should be twice of the vibrator.

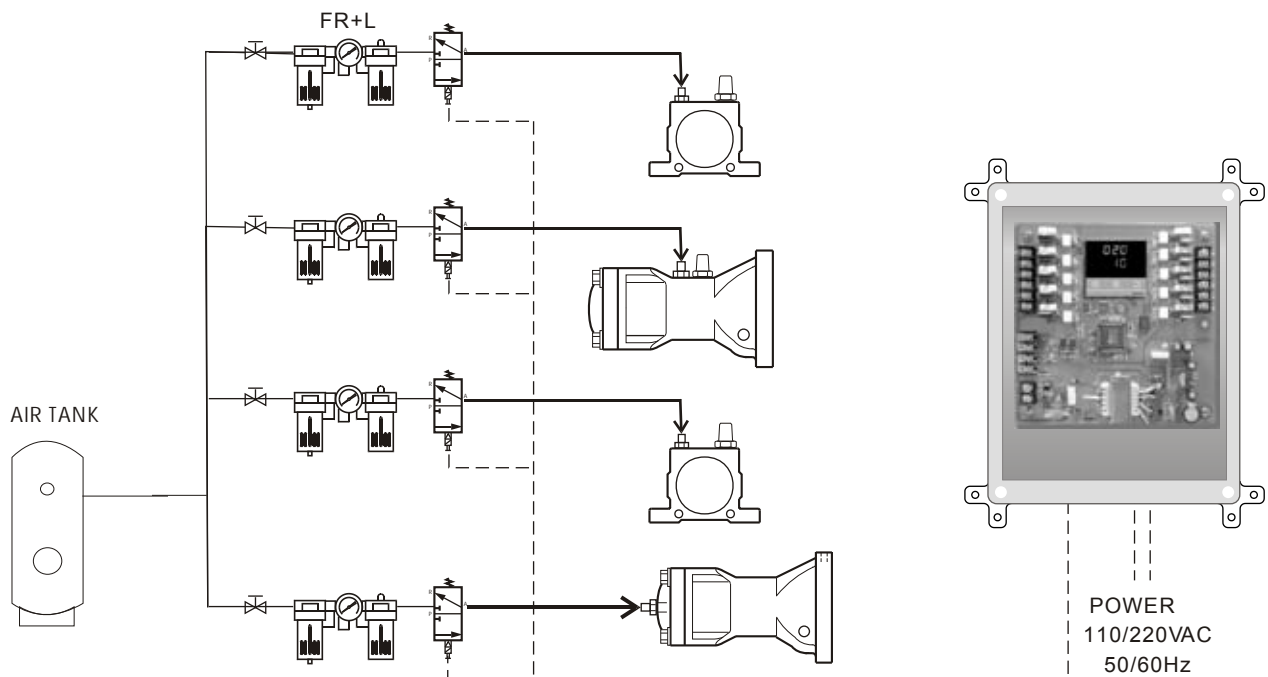

VIBRATOR ACCESSORIES

MUFFLER

Muffler is an accessory that decreases noise when air is exhausted from vibrator.



Type	Model	SL-01	SL-02	SL-03
Range of Service Pressure		0~9(900) kgf/cm ² (kpa)		
Range of Service Temperature		5~60°C		
Material	Body	BRASS		
	Filter Element	BRASS (60mm)		
Orifice	mm ²	17	42	50
Noise Elimination Effect	dB	1	6	13
Connection Port	(PT)	1/8"	1/4"	3/8"

MUFFLER
Material: Plastic

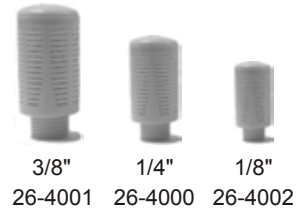

F.R.L COMBINATION (OPTION PART)



AFC

BFC

MODEL	PORT SIZE	LUBRICATOR	REGULATOR	BRACKET	SUITABLE TYPE				
					VK	VR	VT	VP	AH
AFC-200	1/4"	AL-200	AFR-200	M-15E	10	50	10		30
BFC-200	1/4"	BL-200	BFR-200	M-30E	13 16 20 25	65 80	13 16 20 25	30 40 60	40 60 80
BFC-300	3/8"	BL-300	BFR-300	M-30E	32	100	32		

QUICK JOINT (OPTION PART)



MODEL	PU TUBE SIZE	THREAD SIZE
SQC 6-02	OD6xID4	PT 1/4"
SQC 8-02	OD8xID5	PT 1/4"
SQC12-03	OD12xID8	PT 3/8"

SOLENOID VALVE (OPTION PART)

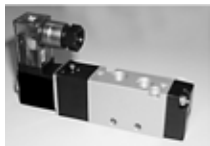

SV-8103

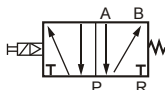

SV-6102TB

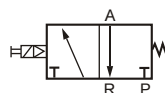

ITEM	MODEL	SV-6102TB	SV-8103
FLUID		AIR	
PRESSURE RANGE		1~7Kgf/cm(100~700Kpa)	
RANGE OF SERVICE TEMPERATURE		0~60°C	
OPERATING METHOD		PILOT OPERATE	
NUMBER OF POSITIONS / PORTS		2/3	2/5
VALVE FUNCTIONS		NORMAL CLOSED	
ORIFICE		14(0.78) mm ² (C V)	18(1.0) mm ² (CV)
MANUAL BUTTON		PUSH AND LOCK	
CONNECTIONS PORT		RT1/4	PT3/8
LUBRICATION		LUBRICATION FREE TYPE	

TROUBLE SHOOTING

Air vibrators are simply structured, which seldom breaks down. Break-down usually arose because of careless installation methods.

Pay attention to F.R.L. combination unit after long time operation.

Trouble shooting	Possible factor	Solution
Vibrator cannot run when switch on	No air supply, or low air supply pressure	To check pressure gauge in F.R.L. Unit and air compressor, the air pressure should be adjusted to exceed 5 kg/cm ² value. Make Sure to turn on the air supply valve and compressor
	Solenoid valve not activated.	To strip air plug of vibrator away, make sure whether air exhaust after solenoid valve is activated
	Exhaust plug of vibrator not being removed	To remove plastic plug of vibrator
	Installation mistake in AC1 series air inlet hole	To make sure air in/outlet installation position is correct.
	Unsuitable solenoid valve will make AH not activating	Air holes have to be 3ways 2 positions or 5 ways 2 positions
Too small vibration force	Install manifold or too many branches on main tube with same cross section size	To enlarge cross section of main tube equal or bigger than sum of manifold or branches tubes. Or to install tubings individually
	Insufficient air supply, Inappropriate tube, solenoid valve, F.R.L unit , or tubing is too long	To make sure applied accessories match to required ones, the length of tubing should not go beyond 5M.
	Wrong VT exhaust and inlet installation	To check pressure of F.R.L. unit and adjust its value higher
	Articles are absorbed by the vibrator	To dismantle the vibrator for checking
	Objects jam in muffler	To check pressure of air supply and adjust it stronger
Vibration noise	Screw loosen	To tight the screws
	U shape steel is not welded well	To weld again
	Vibrators problem	To remove vibrator, then activate it individually. It has to be repaired, if abnormal condition happened while running.
Solenoid valve noise	Articles are in solenoid valve	To replace solenoid valve

EXAMPLES-OF-TANK-MOUNTING

- [FC/FD] Mini Float/Magnetic Float Level Switch
- [FG] Magnetic Float Level Transmitter
- [FF] Side Mounting Float Switch
- [FA/FB] Cable Float Level Switch
- [SP] Thermal Dispersion Flow Switch
- [SF] Paddle Flow Switch
- [SD] Optical Level Switch
- [SE] Rotary Paddle Level Switch
- [SA] Capacitance Level Switch
- [EC] Pressure Level Transmitter
- [LR] Loop Power Indicator
- [SC] Vibrating Probe Level Switch
- [SC] Tuning Fork Level Switch
- [EB] RF-Capacitance Level Transmitter
- [SB] RF-Capacitance / Admittance Level Switch
- [EG] Magnetostrictive Level Transmitter
- [EF] By-Pass Level Transmitter
- [MEF] Mini By-Pass Level Transmitter
- [EA] Ultrasonic Level Transmitter
- [JFR] FMCW Radar Level Transmitter
- [EE] Electromechanical Level Measuring System
- [ED] Speed Monitor
- [SRT/SRS] Conveyer Belt Misalignment Switch & Safety Cable Pull Switch
- [PB/PM] Microprocessor Based Bargraphic Display Scaling Meter
- [BRD/AE] Valve and Controller for Dust Collector System
- [BAS/BAH/BVP] Air Hammer
- [BVK/BVR/BVT] Pneumatic Vibrator

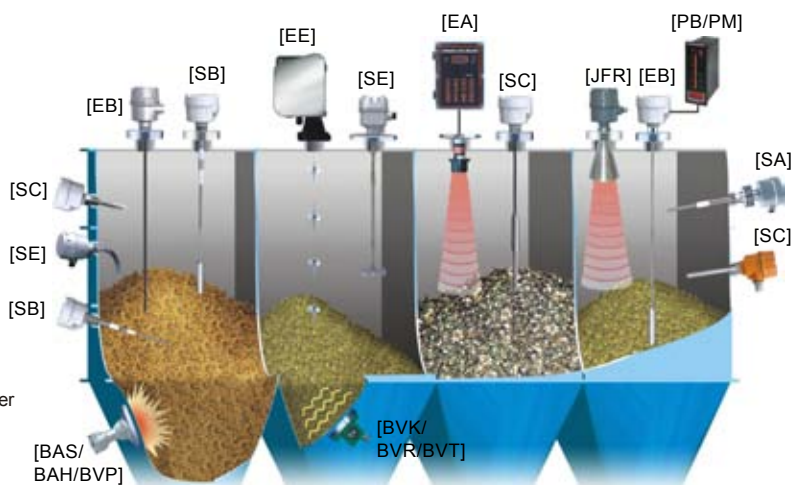
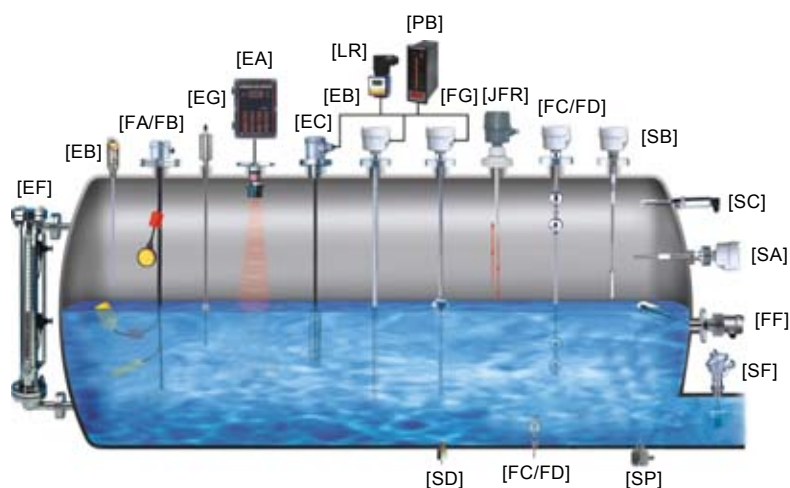

FineTek Co., Ltd.

No.16, Tzuchiang St., Tucheng Industrial Park, New Taipei City 236, Taiwan
 TEL: +886-2-2269-6789 FAX: +886-2-2268-6682
 Email: info@fine-tek.com

Fine automation (ShangHai) Co., Ltd.

No.451 DuHui Rd, MinHang District, Shanghai, China 201109
 TEL: +86-21-6490-7260 FAX: +86-21-6490-7276
 Email: info.sh@fine-tek.com

FineTek Pte Ltd.

No. 11 Kaki Bukit Road 1, #04-01 Eunos
 Technolink 415939, Singapore
 TEL: +65-6452-6340 FAX: +65-6734-1878
 Email: info.sg@fine-tek.com

FineTeK GmbH

Frankfurter Str. 62, OG D-65428 Ruesselsehim, Germany
 TEL: +49-(0)6142-17608-0 FAX: +49-(0)6142-17608-20
 E-Mail: info@fine-tek.de



Distributor:



Gamma Electrónica, S.L.
 CIF: B-20178372
 CALLE OYARZUN, 1 bajo
 20013 SAN SEBASTIAN
 Tel. 943 29 11 02 · fax 943 27 35 77
 www.garmas.com · gamma@garmas.com