

PRINCIPLE

The capacitance level sensor measuring principle is based on the "capacitance effects", when this level sensor is set on a silo, it will be formed a condenser between the detector electrode and the silo wall. The capacitance of this condenser varies proportional to the change of material specific inductivity (DK value) of the material stored in the silo, when the more material substances increased in the silo, the more capacitance value added simultaneously, then it will let his interior circuit's resonant signal to create a bigger amplitude, and such a signal amplitude become more or less than factory default threshold value, the relay device will be energized.

when the sensor probe is not covered, the dielectric constant = 1 (air environment is usually = 1), when the detected probe is covered by substance material, and the changes of its capacitance will be increased and detected, whereby the liquid or powdery level is detected.

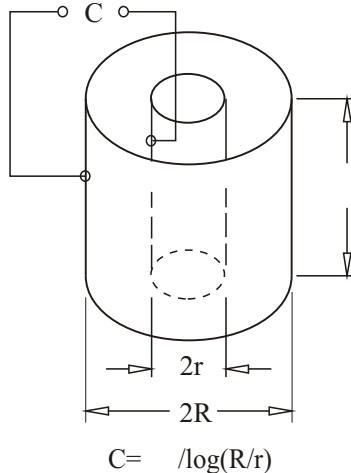

CONSTRUCTION

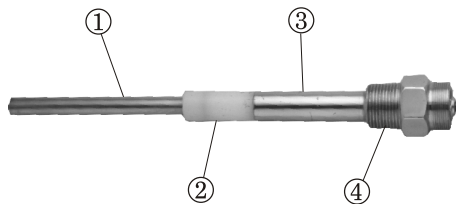

- 1. **Probe** : SUS304 or SUS316
- 2. **Insulation** : UPE or PTFE
- 3. **Grounding Sleeve** : SUS304 or SUS316
- 4. **Connection** : SUS304 or SUS316
1"PT (default) or 3/4"PT(option)

FEATURES AND APPLICATIONS

Because the Capacitance Level Sensor has no moving parts inside the device, it will not be affected by friction. It is suitable for powder or liquid application easy to install. The customer can choose the types for his requirements.

1. **Standard Type (SA110 & SA111 A/B/C)**
Suitable for general use.
2. **Hi-Temp Type (SA120 & SA128 A/B/C)**
Suitable for high temperature environment.
3. **Anti-Corrosion Type (SA130 & SA132 A/B/C)**
Suitable for corrosive environment.
4. **Remote Probe Type (SA140 A/B/C)**
For use with vibrator equipped with tank.
5. **Wire-Probe Type (SA150 A/B/C)**
Suitable for silo or deeper tank.
6. **Plate-Probe Type (SA160 A/B/C)**
Suitable for granules and at lower position of tank side.
7. **Explosion-Proof Type (SA170D ~ SA178D)**
Equipped with SA-75U signal conditioner can be used in hazardous areas.
8. **Anti-Static Type (SA180 & SA181 A/B/C)**
Suitable for electrostatic environment
(It won't be damaged by the electrostatic discharge)

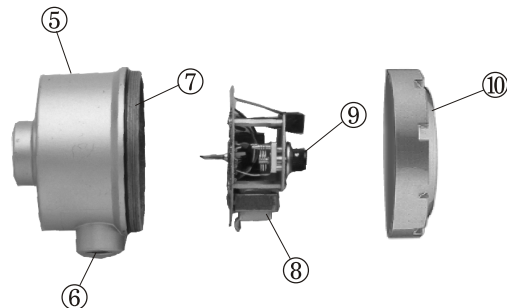

- 5. **Housing** : ADC-12 Aluminum IP65
- 6. **Conduit opening** : 1/2"PF or 3/4"PF
- 7. **O-RING** : NBR
- 8. **PC board** : A, B, C, D Type
- 9. **Sensitivity adjustment** : 10pf (std.), 20pf, 40pf
- 10. **Cover** : ADC-12 Aluminum

TYPE

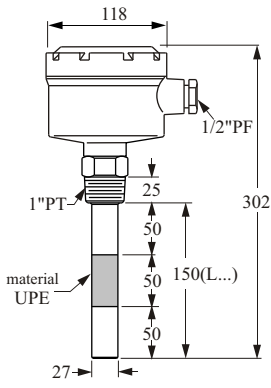
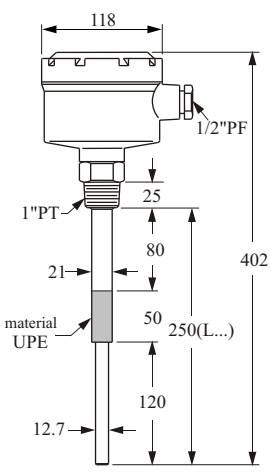
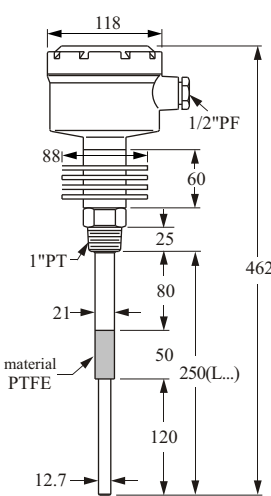
Dimension			
Order No.	SA110 A/B/C [STANDARD TYPE]	SA111 A/B/C [STANDARD TYPE]	SA120 A/B/C [HI-TEMP. TYPE]
Operating Temp.	-20 C~80 C	-20 C~80 C	-20 C~200 C
Probe Material	SUS 304	SUS 304	SUS 304
Insulated Material	UPE	UPE	PTFE
Connection	1"PT screw (SUS)(default) or 3/4" NPT(option)	1"PT screw (SUS)(default) or 3/4" NPT(option)	1"PT screw (SUS)(default) or 3/4" NPT(option)
Sensitivity Range	10pf (std.) 20pf, 40pf (option)	10pf (std.) 20pf, 40pf (option)	10pf (std.) 20pf, 40pf (option)
Weight	Approx. 1.9kg	Approx. 1.9kg	Approx. 2.4kg
Housing Spec.	Aluminum IP65		
Supply Voltage	110/220Vac 10% or 24Vdc		
Delay Time	0~6 seconds		
Power Consumption	2W		
Output Rating	Relay: 5A/240Vac or 5A/30Vdc, SPDT or Transistor: NPN 100mA		

If length of sensing probes longer than 3 meters, please chose 20pf or 40pf sensitivity type.

STANDARD TYPE

Dimension			
Order No.	SA128 A/B/C [SUPER HI-TEMP. TYPE]	SA130 A/B/C [CORROSION-PROOF TYPE]	SA132 A/B/C [CORROSION-PROOF TYPE]
Operating Temp.	-20 C~800 C	-20 C~80 C	-20 C~120 C
Probe Material	SUS 304	SUS 304 Wetted part: PP coating	SUS 304 Wetted part: PVDF coating
Insulated Material	CERAMIC	UPE	UPE
Connection	2-1/2"x5kg/cm ² Flange (SUS)	1-1/2"x10kg/cm ² Flange (PP)	1-1/2"x10kg/cm ² Flange (SUS) with PVDF Washer (5mm)
Sensitivity Range	10pf (std.) 20pf (option)	10pf (std.)	10pf (std.) 20pf (option)
Weight	Approx. 6.5kg	Approx. 2kg	Depend on the length
Housing Spec.	Aluminum IP65		
Supply Voltage	110/220Vac 10% or 24Vdc		
Delay Time	0~6 seconds		
Power Consumption	2W		
Output Rating	Relay: 5A/240Vac or 5A/30Vdc, SPDT or Transistor: NPN 100mA		

If length of sensing probes longer than 3 meters, please chose 20pf or 40pf sensitivity type.

STANDARD TYPE

<p>Dimension</p>			
<p>Order No.</p>	<p>SA140 A/B/C [REMOTE PROBE TYPE]</p>	<p>SA150 A/B/C [WIRE-PROBE TYPE]</p>	<p>SA160 A/B/C [PLATE TYPE]</p>
<p>Operating Temp.</p>	<p>-20 C~100 C</p>	<p>-20 C~80 C</p>	<p>-20 C~80 C</p>
<p>Probe Material</p>	<p>SUS 304</p>	<p>SUS304 cable</p>	<p>SUS 304</p>
<p>Insulated Material</p>	<p>UPE</p>	<p>UPE</p>	<p>UPE</p>
<p>Connection</p>	<p>1"PT screw (SUS)(default) or 3/4" NPT(option)</p>	<p>1"PT screw (SUS)(default) or 3/4" NPT(option)</p>	<p>2-1/2"x 5kg/cm² Flange (SUS)</p>
<p>Sensitivity Range</p>	<p>10pf (std.)</p>	<p>10pf (std.) 20pf, 40pf (option)</p>	<p>10pf (std.) 20pf, 40pf (option)</p>
<p>Weight</p>	<p>Approx. 3kg</p>	<p>Approx. 4.1kg</p>	<p>Approx. 3.2kg</p>
<p>Housing Spec.</p>	<p>Aluminum IP65</p>		
<p>Supply Voltage</p>	<p>110/220Vac 10% or 24Vdc</p>		
<p>Delay Time</p>	<p>0~6 seconds</p>		
<p>Power Consumption</p>	<p>2W</p>		
<p>Output Rating</p>	<p>Relay: 5A/240Vac or 5A/30Vdc, SPDT or Transistor: NPN 100mA</p>		

If length of sensing probes longer than 3 meters, please chose 20pf or 40pf sensitivity type.

INTRINSICALLY SAFE EXPLOSION PROOF TYPE

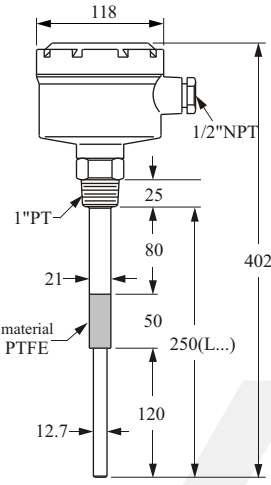
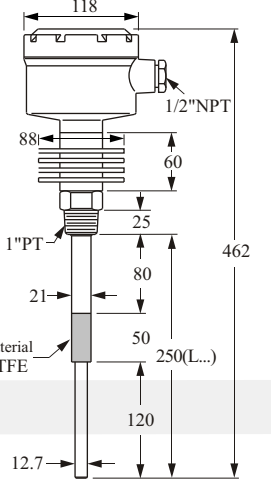
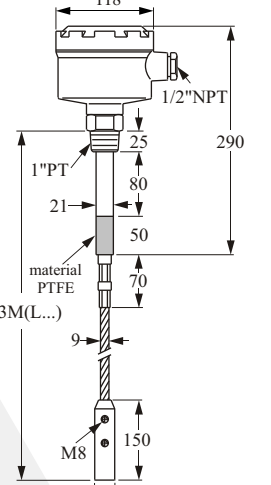
Dimension			
Order No.	EXPLOSION PROOF SA170D (with SA-75U) [STANDARD TYPE]	EXPLOSION PROOF SA172D (with SA-75U) [HI-TEMP. TYPE]	EXPLOSION PROOF SA175D (with SA-75U) [WIRE-PROBE TYPE]
Operating Temp.	-20 C~80 C	-20 C~200 C	-20 C~80 C
Probe Material	SUS 304 / SUS 316	SUS 304 / SUS 316	SUS 304 / 316 cable
Insulated Material	PTFE or UPE	PTFE or UPE	PTFE or UPE
Connection	1"PT screw (SUS)(default) or 3/4" NPT(option)	1"PT screw (SUS)(default) or 3/4" NPT(option)	1"PT screw (SUS)(default) or 3/4" NPT(option)
Sensitivity Range	10pf (std.) 20pf, 40pf (option)	10pf (std.) 20pf, 40pf (option)	10pf (std.) 20pf, 40pf (option)
Weight	Approx. 1.9kg	Approx. 2.4kg	Approx. 4.1kg
Housing Spec.	Aluminum IP65		
Supply Voltage	16~24Vdc		
Enclosure Protection	NEPSI Ex (ia) IIC		
Power Consumption	2W		
Output Rating	Transistor: NPN 100mA		

If length of sensing probes longer than 3 meters, please chose 20pf or 40pf sensitivity type.

INTRINSICALLY SAFE EXPLOSION PROOF TYPE

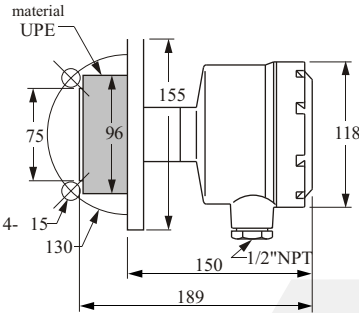
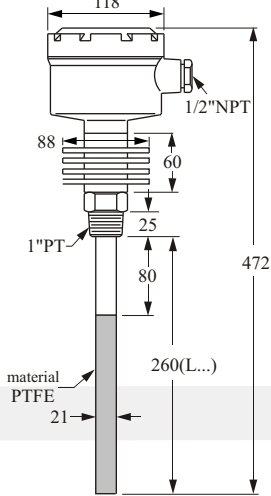
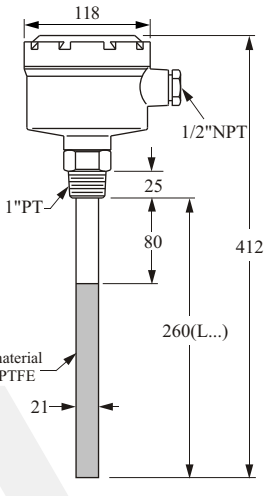
<p>Dimension</p>			
<p>Order No.</p>	<p>EXPLOSION PROOF SA176D (with SA-75U) [PLATE TYPE]</p>	<p>EXPLOSION PROOF SA177D (with SA-75U) [ANTI-STATIC TYPE] HI-TEMP.</p>	<p>EXPLOSION PROOF SA178D (with SA-75U) [ANTI-STATIC TYPE]</p>
<p>Operating Temp.</p>	<p>-20 C~80 C</p>	<p>-20 C~200 C</p>	<p>-20 C~80 C</p>
<p>Probe Material</p>	<p>SUS 304 / SUS 316</p>	<p>PTFE or UPE coating</p>	<p>PTFE or UPE coating</p>
<p>Insulated Material</p>	<p>PTFE or UPE</p>	<p>PTFE or UPE</p>	<p>PTFE or UPE</p>
<p>Connection</p>	<p>2-1/2"x 5kg/cm² Flange (SUS)</p>	<p>1"PT screw (SUS)(default) or 3/4" NPT(option)</p>	<p>1"PT screw (SUS)(default) or 3/4" NPT(option)</p>
<p>Sensitivity Range</p>	<p>10pf (std.) 20pf, 40pf (option)</p>	<p>10pf (std.) 20pf, 40pf (option)</p>	<p>10pf (std.) 20pf, 40pf (option)</p>
<p>Weight</p>	<p>Approx. 3.2kg</p>	<p>Approx. 3.1kg</p>	<p>Approx. 2kg</p>
<p>Housing Spec.</p>	<p>Aluminum IP65</p>		
<p>Supply Voltage</p>	<p>16~24Vdc</p>		
<p>Enclosure Protection</p>	<p>NEPSI Ex (ia) IIC</p>		
<p>Power Consumption</p>	<p>2W</p>		
<p>Output Rating</p>	<p>Transistor: NPN 100mA</p>		

If length of sensing probes longer than 3 meters, please chose 20pf or 40pf sensitivity type.

ANTI-STATIC TYPE

Dimension		
Order No.	SA180 A/B/C [ANTI-STATIC TYPE]	SA181 A/B/C [ANTI-STATIC TYPE] HI-TEMP.
Operating Temp.	-20 C~80 C	-20 C~200 C
Probe Material	UPE coating	PTFE coating
Insulated Material	UPE	PTFE
Connection	1"PT screw (SUS)(default) or 3/4" NPT(option)	1"PT screw (SUS)(default) or 3/4" NPT(option)
Sensitivity Range	10pf (std.) 20pf (option)	10pf (std.) 20pf (option)
Weight	Approx. 2kg	Approx. 2.5kg
Housing Spec.	Aluminum IP65	
Supply Voltage	110/220Vac 10% or 24Vdc	
Delay Time	0~6 seconds	
Power Consumption	2W	
Output Rating	Relay: 5A/240Vac or 5A/30Vdc, SPDT or Transistor: NPN 100mA	

If length of sensing probes longer than 3 meters, please chose 20pf or 40pf sensitivity type.

SA-75U INTRINSIC SAFE SIGNAL CONDITIONER

SA-75U Zener barriers inside provide intrinsic safety to SA17 D type level sensor. The unit works via a current-limiting feature which protects the device from damage by emission of sparks.

1. Supply voltage : 110 / 220Vac
2. Power consumption : 2W
3. Input signal : NPN transistor
resistance $R_i = 500$
4. Output voltage : 16~24 Vdc
5. Short circuit current : 25mA max.
6. Relay output : SPDT
10A /30Vdc
10A /220Vac
7. Operating temp. : -20 C ~ 60 C
8. Weight : 0.3 kg
9. Enclosure rating : Ex (ia) IIC T6

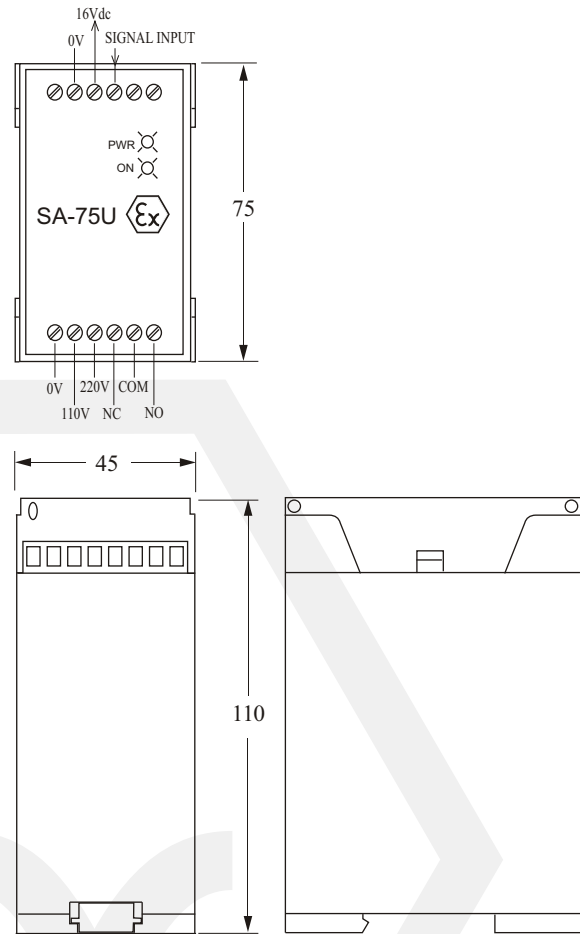

WIRING CONFIGURATION

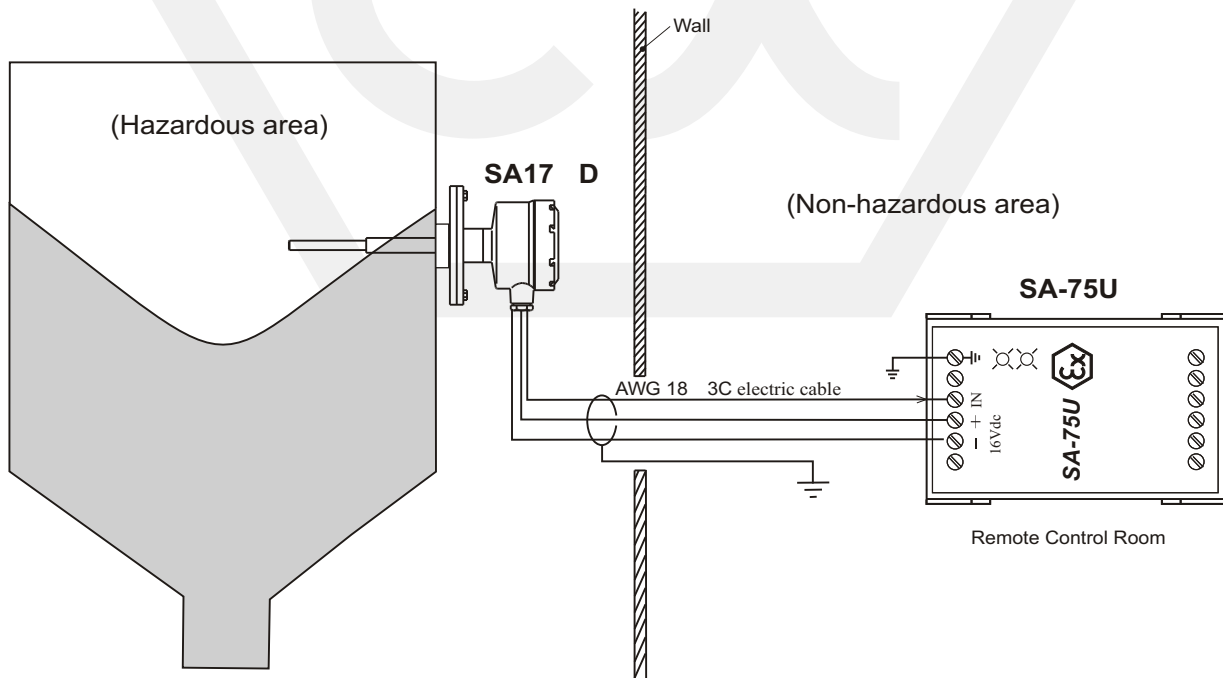

ADJUSTMENT

COARSE CALIBRATION

Set the "Sensitive ADJ. " to the "H" position. Then use a screw driver to adjust the "Coarse" until indicator is lighted. At last check "Indicator" is light or not by adjust the "Sensitivity Adj" knob, if not, repeat procedure.

SENSITIVITY ADJUSTMENT

When the material is out of contact with probe will extinguish the "Indicator". When the material is in contact with probe will illuminated the "Indicator " lamp, at this time please adjust "Sensitivity ADJ." until lamp is in extinction. And then set "Sensitivity ADJ." in the middle between "H" and extinction position. e.g. If extinction position is 10p, you should set "Sensitivity ADJ." in "75" position.

DELAY FUNCTION CALIBRATION

The default setting is 0 second, here at the material is in contact with probe will illuminate "Indicator" lamp and energize relay. When the user need to use this delay function, please set timer in clockwise. The relay will energized after "Indicator" illuminate for several seconds if set timer more than 0 second. The delay function is suitable for variable material level. e.g. liquid tank equip with agitator.

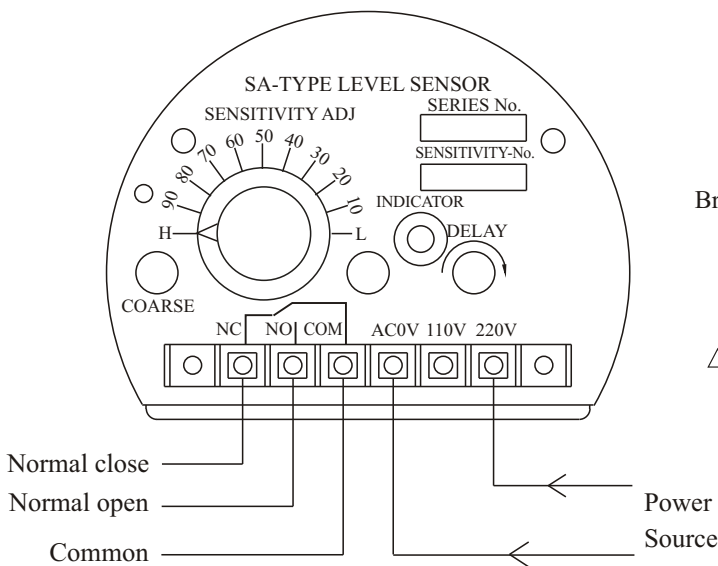

SA110, 120, 130, 150, 160, 17 , 180 A/B/C/D

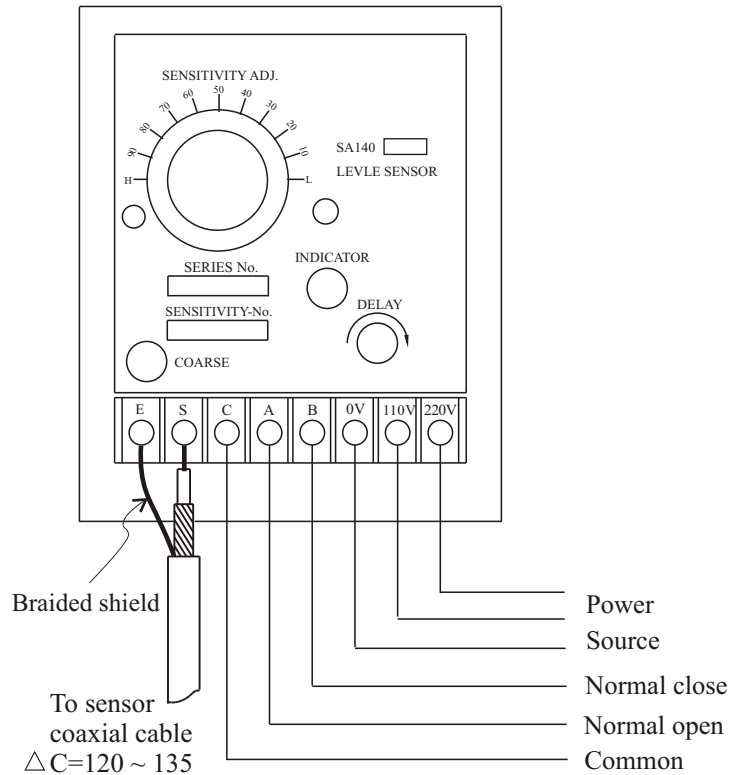

Remote Probe Type (SA140 A/B/C)

INSTALLATION NOTICE

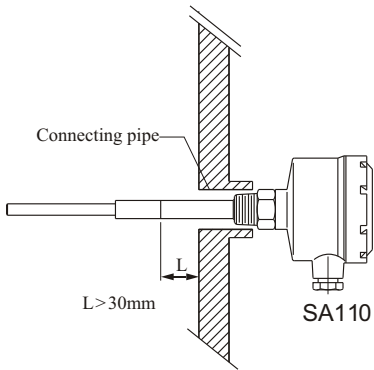

The insensible portion should be mounted to protrude 30mm from the vessel wall. That's to prevent malfunction from a fill material or an insufficient clearance between probe and connection pipe.

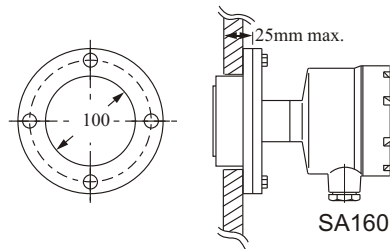

SA160 to be mounted properly, the vessel walls should not exceed 25mm.

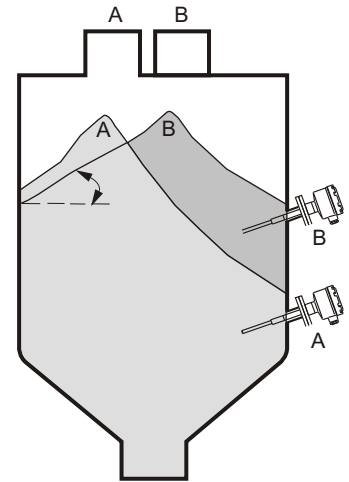

To prevent false readings, users have to make sure the material flows symmetrically. If the inlet is not located in the center portion of the tank roof, check the flow pattern (angle) of your material and place the probe in the appropriate location.

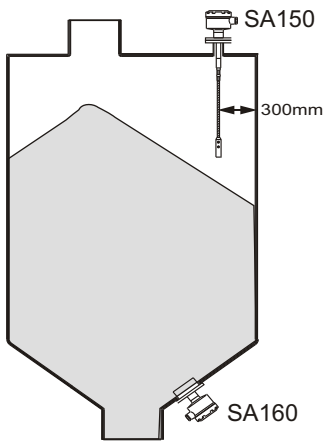

If the probe is mounted on the top, make sure the length of probe long enough to touch the highest level of raw material. SA150 type must have at least 300mm from the electrode probe to the silo wall. SA160 type is usually installed at the lower of tank side.

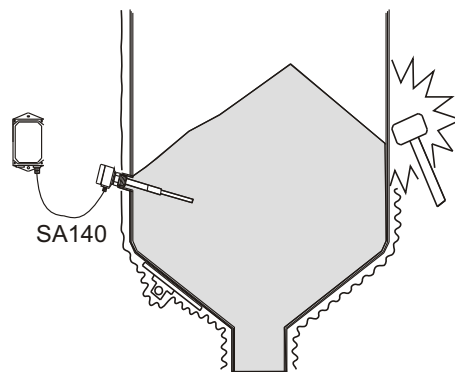

For Non-Stationary or vibrating environment, a separate control unit such as the SA140 is suggested.

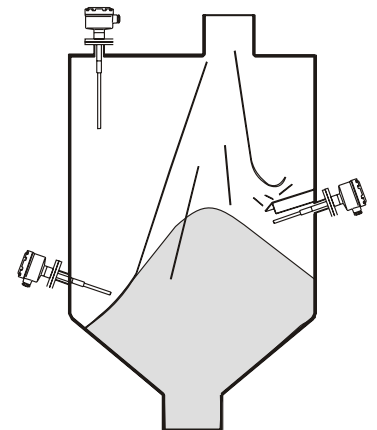

It is suggested to install the probe away from the inlet to reduce the risk of inflowing material damaging the probe. If the probe is near an inlet, it is recommended to place a protective cover 200mm above the probe. The cover should be parallel to the probe and the same length.

INSTALLATION NOTICE

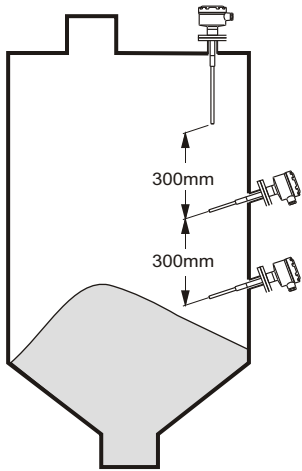

If two parallel probes are mounted, they must be installed separately at least 300 mm to minimize interference .

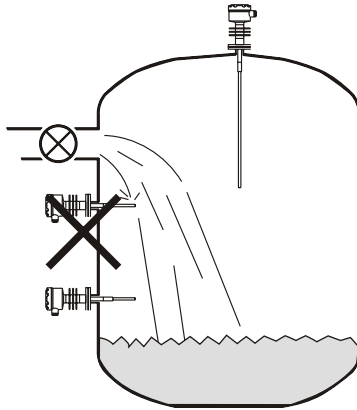

The probe should not be mounted underneath a liquid inlet, otherwise it will switch on erroneously.

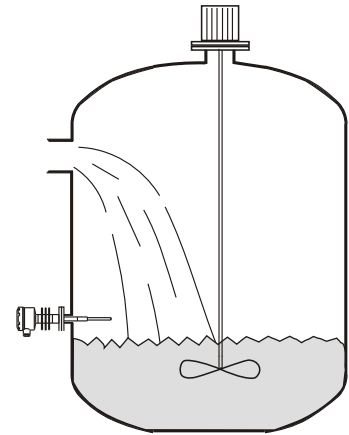

If the tank equips with agitator, please use the time-delay type (SA -A~D) to prevent fault level detection.

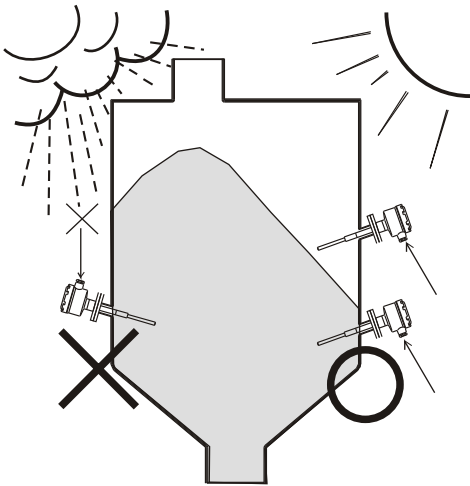

The cable inlet should face downward to avoid rain damage. Tighten the cable with the connecting part.

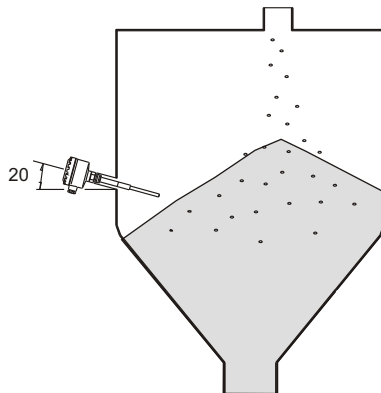

Mounting the probe at a 20 degree incline will optimize the results and increase sensitivity. It also won't be damaged by the inflowing material.

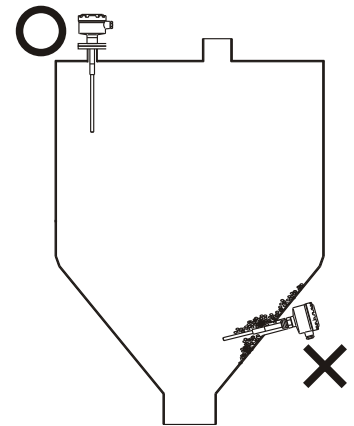

Mounting the probe at top of tank can avoid material bridges from forming. It's helpful to record accurate measurements.

ORDER INFORMATION

SA 110 A DQ 0250

Model

- 110 --- Standard Type
- 120 --- Hi-temp. Type
- 130 --- Corrosion Proof Type
- 140 --- Remote Probe Type
- 150 --- Wire Probe Type
- 160 --- Plate Type
- 170 --- Explosion Proof Type
- 180 --- Anti-static Type

Terminal Arrangement

- A---110/220Vac, Relay output
- B---24Vdc, Relay output
- C---24Vdc, NPN transistor output
- D---Designed for use with SA-75U

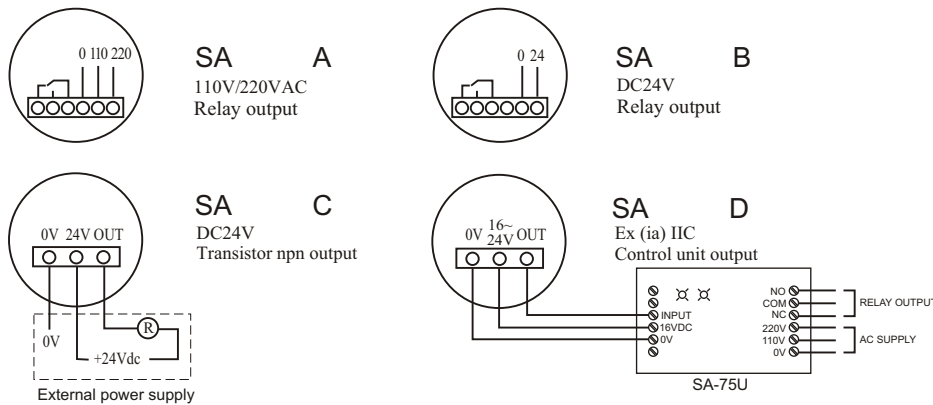

Connection

C---3/4"(20A)	M---5kg/cm ²	W---PN 10
D---1"(25A)	N---10kg/cm ²	X---PN 16
E---1-1/2"(40A)	O---150 Lbs	Y---PN 25
F---2"(50A)	P---300 Lbs	Z---PN 40
G---2-1/2"(65A)	Q---PT	
H---3"(80A)	R---PF	
I---4"(100A)	T---BSP	
J---5"(125A)	U---NPT	
K---6"(150A)	V---GAS	
S---Others	S---Others	

Probe Length (mm)

Tolerance of the total product length is 5mm.
 Characteristics, specifications and dimensions are subject to change without notice.
 Please contact your nearest distributor office for further informations.