



Electromechanical Level Measuring System

PRODUCT INTRODUCTION

WORKING PRINCIPLE

FineTek's Electro-Mechanical Level Measuring System (EE300 series) consists of plumb, cable wire, measuring pulley, position sensor, and control board to measure the material level. It senses the weight status and count the cable wire length from the device to the level of material. The EE series equips with robust position sensor to calculate the rotation of pulley which can be operated in harsh environment. Moreover, it can connect with FineTek's material measurement system (MMS) to build an interactive control system, save the operator patrolling time and maintenance.

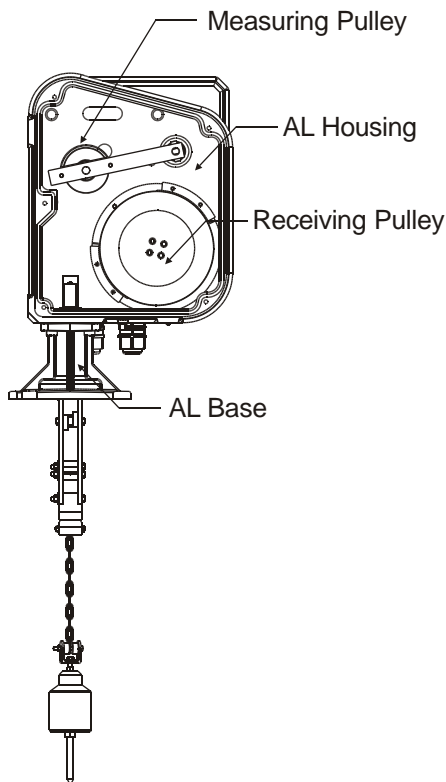

Rear View: Wiring Mechanism

APPLICATION

- Widely utilized in mining, cement, chemical, and feed industries.
- Suitable for applications of dusty silo, pellet silo, solids silo, liquid silo, unsealed, or vacuum sealed silo.

FEATURES

- Measurement immune from the interference of environment such as sound waves, dust, capacitance, or temperature change.
- User-friendly in touch buttons with microprocessor-based calculation design.
- High level and low level alarm.
- LCD Dot matrix: 8 x 2.
- Analog output: 4-20mA dc.
- Pulse output:
 - Transistor output NPN/PNP (10mm/pulse)
 - Relay output 3A/250Vac (100mm/pulse)
- Cable Break Alarm: System will detect cable broken during measuring.
- Plumb Buried Alarm: System will detect plumb buried by the medium.
- Four Start Modes: auto start, manual start, intelligent start, and external triggered start.
- Intelligent Start: Measuring interval is inverse proportional to medium level.
- Auto Return Setup: Prevent sensing weight from buried or sliding into the tank pivot and avoid damage facility equipment while tank is empty.
- Material Fill-Up Protection: Reduce the possibility of plumb being buried.
- Measuring range of 30m (Standard), max. up to 40 m.
- RS485 MODBUS communication protocol.
- Various selections of .

Product Testing Standards

- Protection Rating: IP66(IEC60947-2)
- IEC Standards for Voltage: IEC60947-2
- IEC Standards for Isolation: IEC60092-504
- IEC Standards for changes in power supply: IEC60092-504
- IEC Standards for power supply failure: IEC60092-504

SPECIFICATION

No.	Category	Specification	
1	Power Supply	100~240Vac± 10%, 50/60 Hz	
2	Transistor Measuring Resolution	± 3pulse(version with10mm/pulse)	
3	Relay Output Measuring Resolution	± 1pulse(version with100mm/pulse)	
4	Measuring Speed	0.23m/s	
5	Analog Output	0/4-20mA ± 1%	
6	Pulse Output	1. NPN / PNP (10mm/pulse) System sends pulse output every 1cm. Each pulse has interval of 10ms. 2. Relay 3A/250Vac (100mm/pulse) System sends pulse output every 10cm. Each pulse has interval of 15ms.	
7	Display	LCD (Dot matrix , 8 X 2)	
8	Status LED	1.Lock (Fill-Up Protection) 2.RUN 3.Buried 4.Break 5.Auto 6.High Alarm 7.Low Alarm	(Red) On (Yellow) On (Red) Blink for 1 second (Red) Blink for 2 seconds (Blue) On (Red) On (Red) On
9	Ambient Temperature	-35°C- 60°C	
10	Operating Temperature	-35°C- 80°C	
11	Measuring Range	30m Max	
12	Protection Level	IP66	
13	Relay Output	SPDT 3A/250Vac X 3 1. HI Alarm 2. LO Alarm 3. Buried: Blink for 1 second when alarm triggers Break : Blink for 2 seconds when alarm triggers Lock : LED on when alarm triggers	
14	Anti-Dew Heater	Start heating <16°C (prevent frostbite, prevent dew) in 100 W optional	
15	Cable Break Detection	Yes	
16	Sensing Weight Buried Detection	Yes	
17	Manual/Auto Measuring Mode	Yes (0.1-99h)	
18	Motor Protection	Yes	
19	Malfunction Diagnosis Display	Yes	
20	Material Fill-Up Protection	Yes	
21	Communication Protocol (RS485)	Yes	Frame C8N1.C8N2.C801.C8E1.C7N2.C701.C7E1.C702. C7E2.
			Baudrate 1200.2400.4800.9600. 11520. 14400.19200.28800.57600
22	Intelligent Start	Measuring interval is inverse proportional to medium level.	
23	Reset Output	Reset (3A/250Vac)	
24	Cable Wire	1.2mm ^φ	

SKETCH & DRAWING/ DIMENSION

Sketch & Drawing

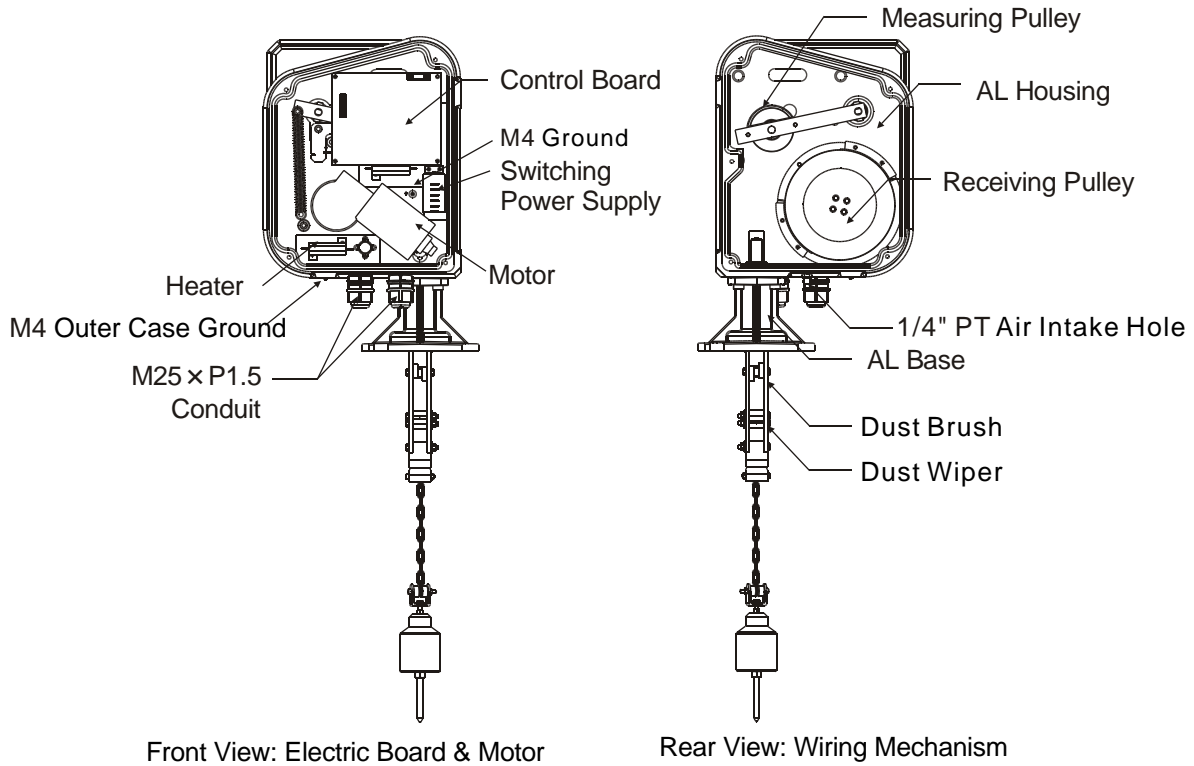

Dimension

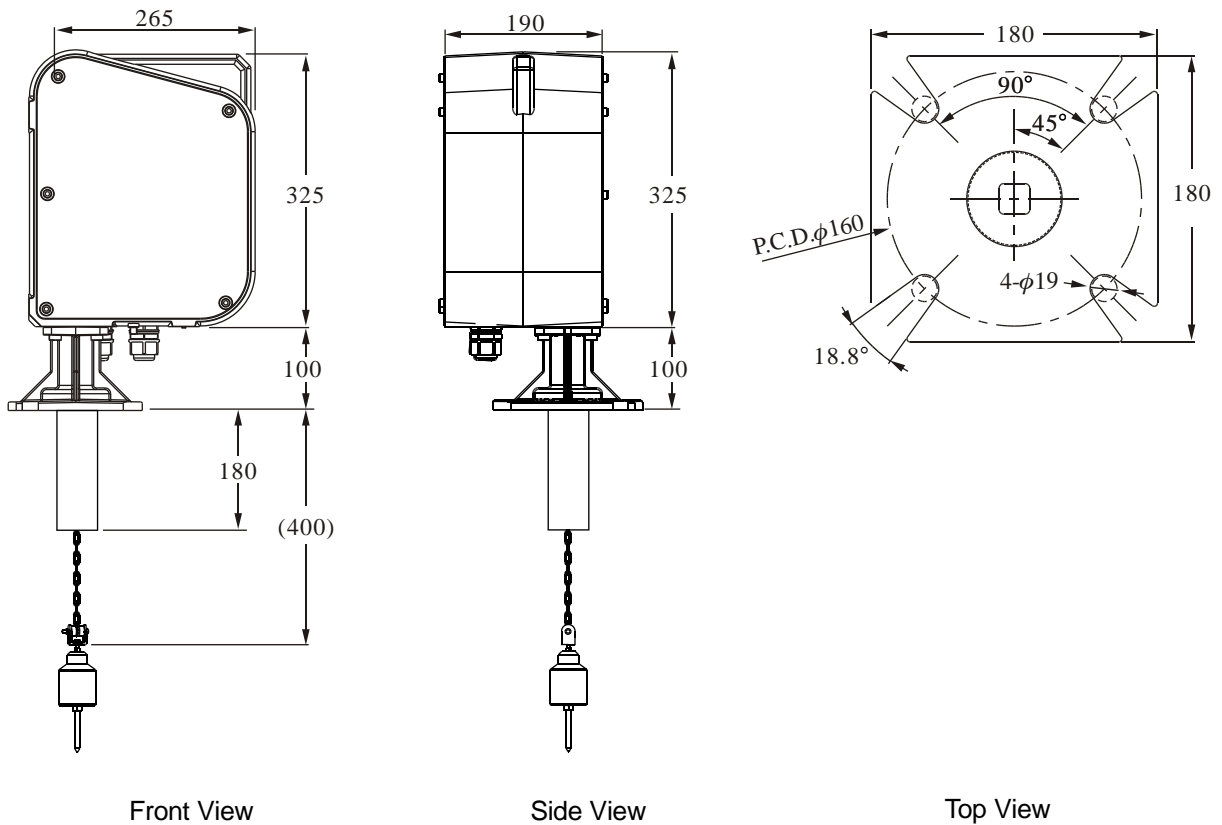

WIRING DIAGRAM/ DESCRIPTION OF PANEL

Wiring Diagram

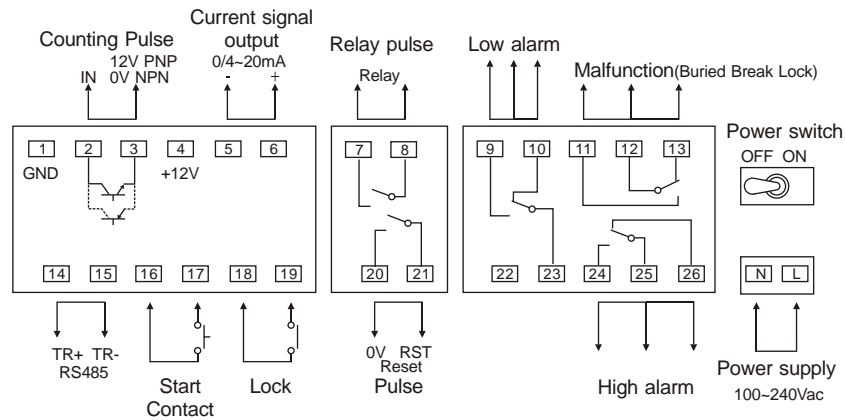

Description of Panel

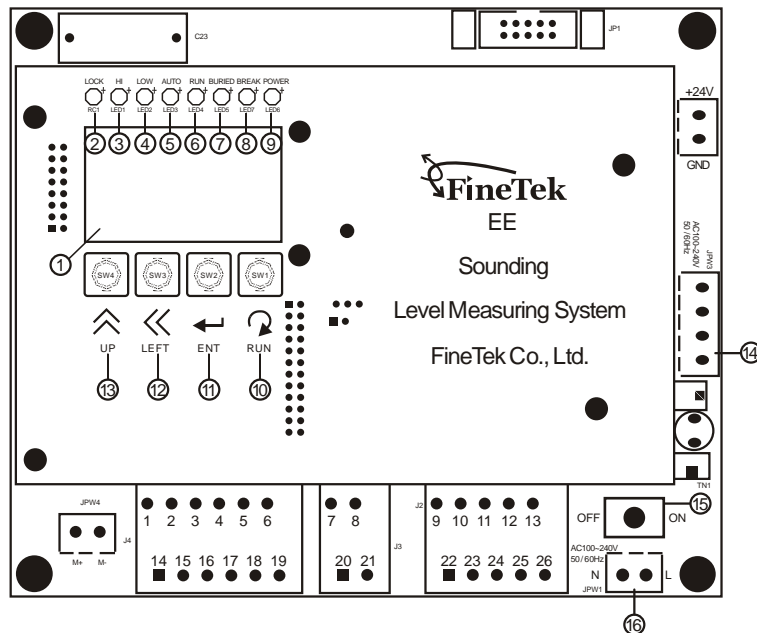

- ① Characteristic LCD (Dot matrix , 8 × 2), provides the status, level command and error message.
- ② Material Fill-Up Protection Indicator (LOCK), the EE will be turned off and hold LOCK indication while the reservoir is filling up procedure.
- ③ High Level Alarm Indicator (H1), light on if the material level exceeds the preset high threshold.
- ④ Low Level Alarm Indicator (LOW), light on if the material level is below the preset low threshold.
- ⑤ Auto Start Indicator (AUTO), light on to indicate EE is in automatic operation mode.
- ⑥ Start Indicator (RUN), light on if the EE is in measuring period, and it turns light off status while the measurement completed.
- ⑦ Weight Head Buried (BURIED), blink light on /off in 1 sec period to warn operator, the LCD will show BURIED message.
- ⑧ Cable Break Indicator (BREAK), blink light on /off in 2 sec period to warn operator, the LCD will show BREAK message.
- ⑨ Power Indicator (POWER), "Light On" for power on and "Light Off" to indicate power off.
- ⑩ "Start", start the operation.
- ⑪ "Enter", acts as "confirm button" at setting mode and as "page select button" at menu mode.
- ⑫ "Shift", acts as "decimal shift" while enter digits and as "enter button" at menu mode.
- ⑬ "UP", acts as "Increment button" while enter digits and as "Escape button" at menu mode.
- ⑭ Terminal (H1.H2) for heater.
- ⑮ Power switch: to turn on, turn off power
- ⑯ Power connector (L.N), accepts the power of 100~240Vac, 50/60Hz ◦

PROGRAMMING GUIDE

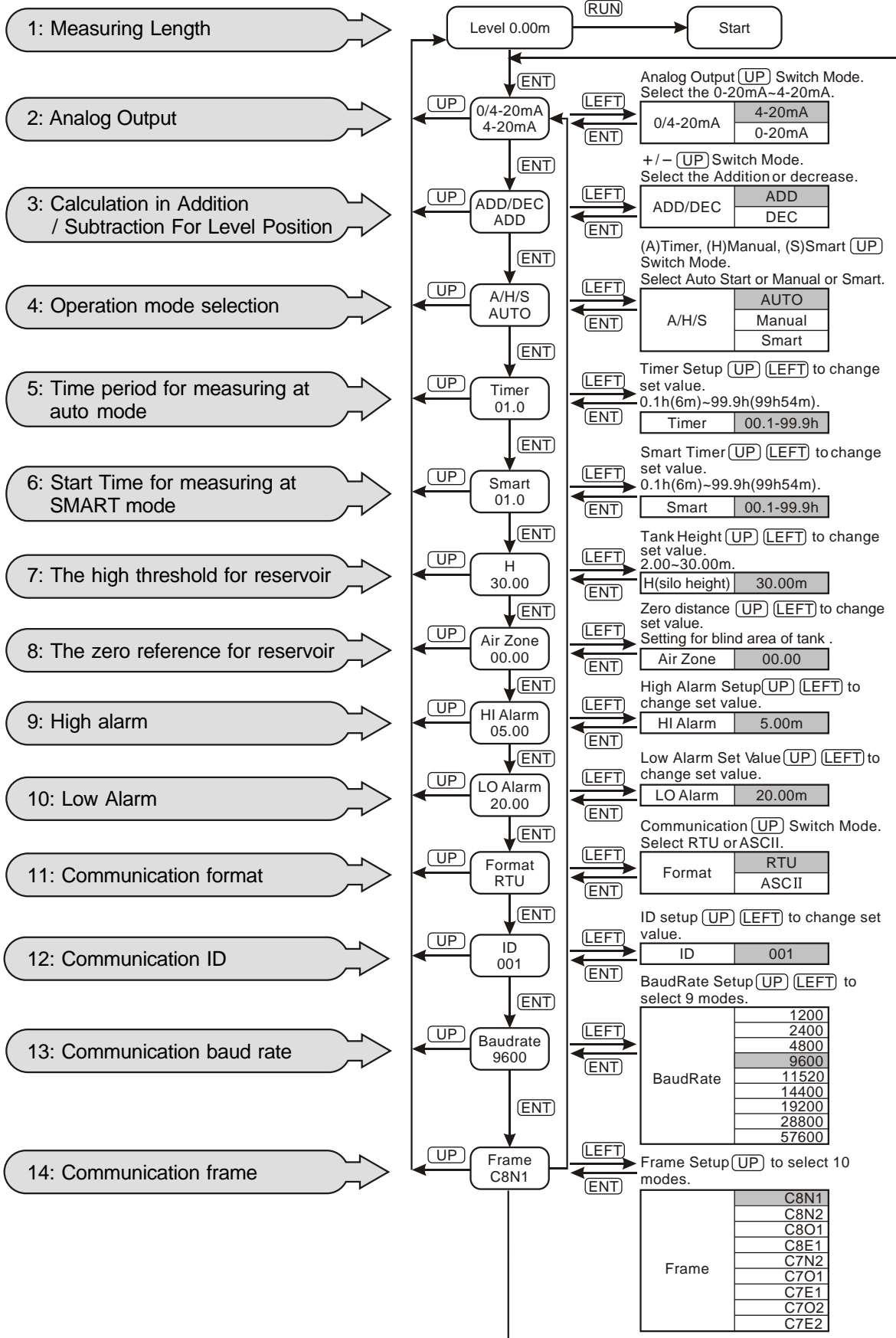

SETTING PROCEDURE

Caution

While the reservoir or storage is in empty, or the field level is not in normal status. please don't start this EE300. Be sure the and reservoir is in normal and avoid from the sensing weight head has the possibility of being stuck by conveyer or stirred by any mechanism near inlet or outlet. Before setting, user should note that the measuring level should not exceed the bottom of reservoir or storage, and not install EE300 accompany with any obstacle around.

Definition

K Tank Height:

distance between connecting flange to tank outlet

S Blind Distance:

distance from connecting flange to the tip of the weight

Z Safety Distance:

To avoid obstacle and prevent weight sliding into the outlet.

H Measuring Height:

Full measuring range from drop and return with full pulse signal record.

A Air Zone(deadband):

Variation of tank capacity and real medium level.

Default setting is 0.

H Effective measuring distance:

distance will change according to A value and corresponds to 0/4~20mA output signal.

Hi Alarm: High level alarm setup.

Lo Alarm: Low level alarm setup.

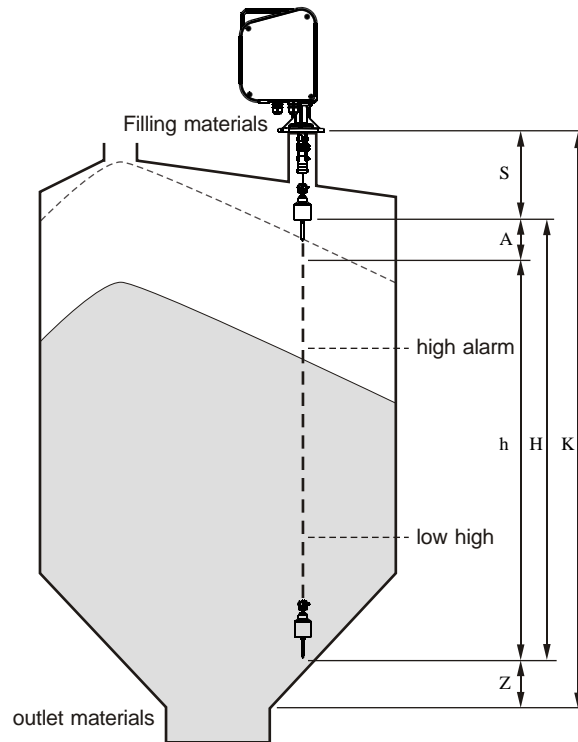

Example (Smart Mode)

Smart mode operates the measurement according to the capacity and level of reservoir. In smart mode, the next measuring time period is depend on the current level distance measured. It is roughly a step by step (0.1 hr for each step), in quasi-linear relation, as indicated below. (Note: Timer value should be larger than Smart value).

Example:

Timer=1.1h? **Smart**=0.1h? **H**=10m

Measuring time at next, $t = (\text{Smart} + (A/H) \times (\text{Timer} - \text{Smart}))$

Where the **Timer** is the maximum standby time to detect, **Smart** is the minimum standby time to detect, A is the measuring level distance, H is the High Alarm value. T is the next measuring time since this measurement.

Ex: A is 10m, the next start detect time is $0.1 + 1 \times 1 = 1.1\text{h}$

A is 1m, the next start detect time is $0.1 + 0.1 \times 1 = 0.2\text{h}$

INSTALLATION

Installation Position

- Installation position should be away from the inlet or outlet of reservoir at least 1.2 m, and avoid from interfering with the conveying system to damage facility.
- Reservoir or tank equipped with observation window is suggested; it will be beneficial for maintenance in future. The installation location should be away from the ladder, frame or any protrusion. The minimum distance between the EE300 center and tank wall should be 1m or more.
The optimal position is at the average depth of
- measured material, it will generally locate at mountainside between the peak and bottom (the cone angle from by the pouring process), indicates below.

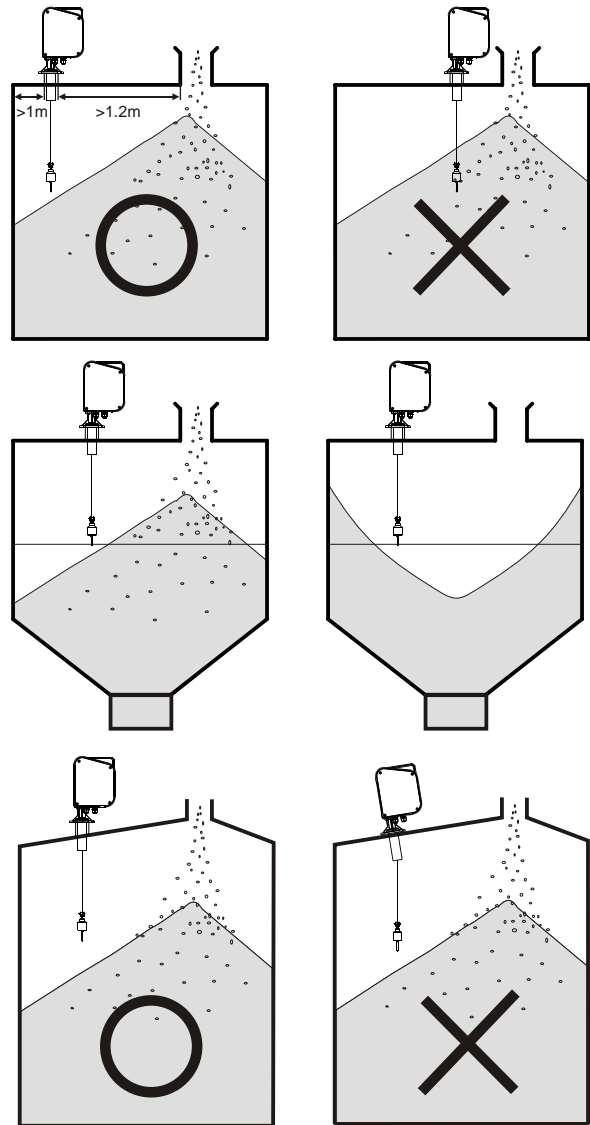

Installation Instruction

- The flange should be mounted at horizontal. Besides, the housing and cable wire should be keep vertical direction related to measured material level. It should be carefully checked if the flange can let the wire cable move free and no rub against the body.
- On demand, user may connect an extended tube to connect the flange. If you do that, keep in mind that minimum diameter should not be less that 4". For leakage, FineTek suggests the customer to use O-ring seal or washer between the flange
- connections and secure it indeed.

Caution

- The position and method of inlet condition installation:
1. Direct Injection: Please install at either side of inlet.
 2. Vortex Injection: Please install at left side of inlet in case of clockwise direction or at right side of inlet in case of counter-clockwise direction.
 3. Sprinkle Injection: Please install furthest at the opposite to inlet to avoid impact by injection.
- During installation, user should carefully check the cable wire is winded up well in pulley set and no fold, broken, or any abnormal compress on the cable wire.
 - The cable wire should put on the hole of weight head connect and be secured indeed by screwdriver.
 - Firmly secure the screws to fix the front cover and body, otherwise the dust or powder will pour into the electric board.
 - The opening portion for the weight head and cable wire must be larger than 104 mm.

Wiring Instruction

FineTek suggests 0.75mm² non-twist multiple-cores isolated electric wire to connect with the terminal block. The power line should be separated with the signal lines. It should leave a flexible length of electric wire to avoid pull and drag the electric board. Peer off the skin of electric wire in appropriate length, not leave to much naked wire to avoid from the electric close. All naked wire should be well welding and secure well by terminal block. Wiring label should be clearly identified and in correct connect. The wiring diagram is Below.

ORDER INFORMATION

EE300-□-□□□-□□

TEMPERATURE CONTROL

- 0:None
- 1:Yes

CONNECTION

	00	01
Name	Standard	Customization
Type		

※Flanges For Standard Model :

- 4"x5kg/cm²、4"x10kg/cm²、4"x16kg/cm²、4"x20kg/cm²、4"x150Lbs
- DN100 PN6、DN100 PN10、DN100 PN16、DN100 PN25、DN100 PN40

SENSING WEIGHT TYPE

	A	B	C	D
Name	Aluminum Alloy	Stainless probe steel float type	Umbrella	Plastic Auto-Fall-Off
Type				

※ Custom made is available for sensing weight

MEASURING RANGE (m)

- 02:2m(min.)
- 30:30m(max.)

EXAMPLES-OF-TANK-MOUNTING

- [FC/FD] Mini Float/Magnetic Float Level Switch
- [FG] Magnetic Float Level Transmitter
- [FF] Side Mounting Float Switch
- [FA/FB] Cable Float Level Switch
- [SP] Thermal Dispersion Flow Switch
- [SF] Paddle Flow Switch
- [SD] Optical Level Switch
- [SE] Rotary Paddle Level Switch
- [SA] Capacitance Level Switch
- [EC] Pressure Level Transmitter
- [LR] Loop Power Indicator
- [SC] Vibrating Probe Level Switch
- [SC] Tuning Fork Level Switch
- [EB] RF-Capacitance Level Transmitter
- [SB] RF-Capacitance / Admittance Level Switch
- [EG] Magnetostrictive Level Transmitter
- [EF] By-Pass Level Transmitter
- [MEF] Mini By-Pass Level Transmitter
- [EA] Ultrasonic Level Transmitter
- [JFR] FMCW Radar Level Transmitter
- [EE] Electromechanical Level Measuring System
- [ED] Speed Monitor
- [SRT/SRS] Conveyer Belt Misalignment Switch & Safety Cable Pull Switch
- [PB/PM] Microprocessor Based Bargraphic Display Scaling Meter
- [BRD/AE] Valve and Controller for Dust Collector System
- [BAS/BAH/BVP] Air Hammer
- [BVK/BVR/BVT] Pneumatic Vibrator

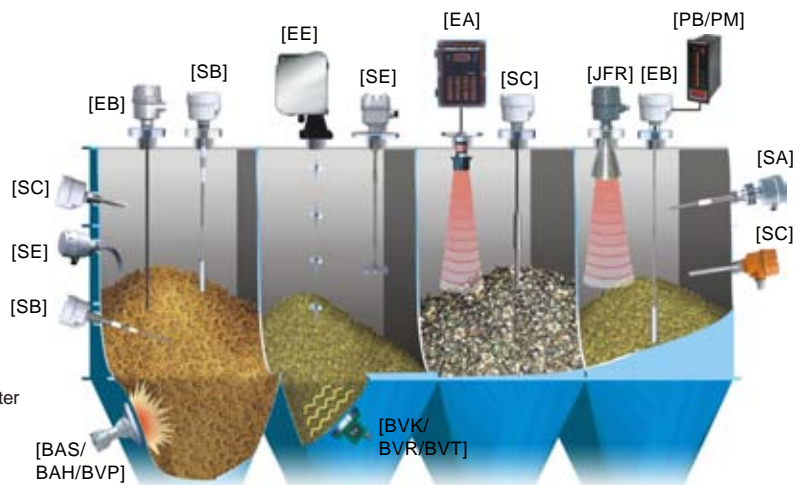
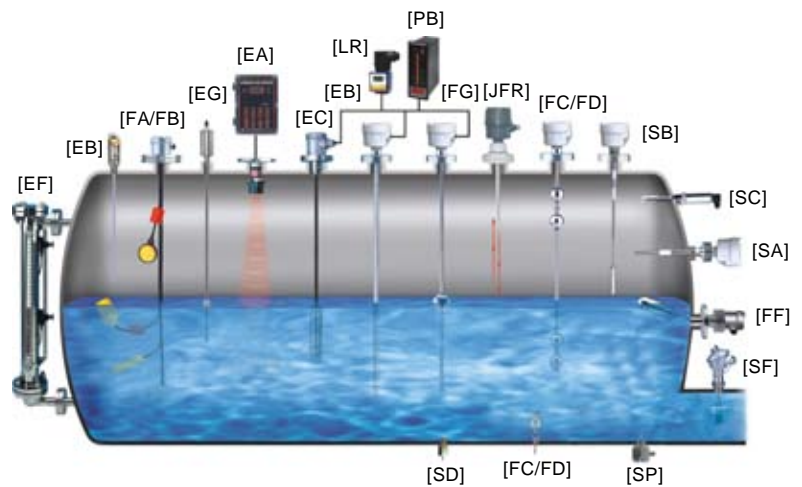

FineTek Co., Ltd.

No.16, Tzuchiang St., Tucheng Industrial Park, New Taipei City 236, Taiwan
 TEL: +886-2-2269-6789 FAX: +886-2-2268-6682
 Email: info@fine-tek.com http://www.fine-tek.com

Fine automation (ShangHai) Co., Ltd.

No.451 DuHui Rd, MinHang District, Shanghai, China 201109
 TEL: +86-21-6490-7260 FAX: +86-21-6490-7276
 Email: info.sh@fine-tek.com

FineTek Pte Ltd.

No. 11 Kaki Bukit Road 1, #04-01 Eunos
 Technolink 415939, Singapore
 TEL: +65-6452-6340 FAX: +65-6734-1878
 Email: info.sg@fine-tek.com

FineTeK GmbH

Frankfurter Str. 62, OG D-65428 Ruesselsehim, Germany
 TEL: +49-(0)6142-17608-0 FAX: +49-(0)6142-17608-20
 E-Mail: info@fine-tek.de



Distributor:



Garma Electrónica, S.L.
 CIF: B-20178372
 CALLE OYARZUN, 1 bajo
 20013 SAN SEBASTIAN
 Tel. 943 29 11 02 · fax 943 27 35 77
 www.garmasl.com · gamma@garmasl.com