



Mini Float Level Switch

PRODUCT INTRODUCTION

■ INTRODUCTION

Since technologies of the product have more and more advance, the products need comply with a requirement for more convenient, safe and low cost.

The float switches are extremely compact, simple and are easy to install on any small space.

These switches are not effected by electrical interference. They can withstand to chemicals, high temperatures and pressures if the correct material of float switch is selected by the customers.

■ LIQUID PROPERTIES AND FLOATS

When the liquid specific gravity is less or more than the water, the float on the switch will either increase or decrease the immersion depth. The switch actuation level will also change.

All actuation levels are assumed with the water (SG=1). If your liquid has a different specific gravity, you should not specify the float specific gravity more than liquid, that will not cause the float rise with the liquid level. The reed switch inside the stationary stem will not be activated by the magnet inside the float.

If your liquid has a high viscosity, you should specify largest size float that will provide a greatest buoyant force to ensure the units operate normally.

Because the float switches are activated by the magnetic field of permanent magnet inside the float, make sure the liquid is no iron powder or magnetic material to avoid magnetic interference.

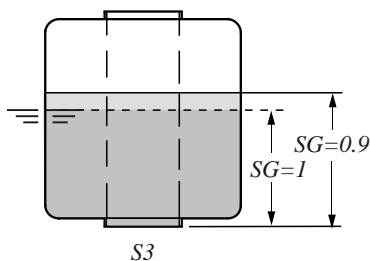

(Fig. 3)

■ PRINCIPLE

Fig. 1 illustrates the method of pivot actuation (such as the FCH TYPE float switches). When the magnetic field of permanent magnet inside the float is moved into to the proximity of the reed switch inside the stationary stem, the reed switch "snaps" the contact together and closes the electrical circuit. When the magnetic field is moved away from the reed switch, the reed switch does not touch. The circuit is open.

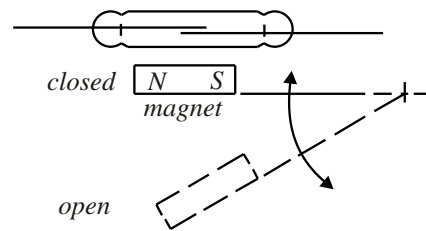

(Fig. 1)

Fig. 2 illustrates the method of perpendicular actuation (such as the FC V TYPE float switches). When the magnetic field of ring magnet inside the float is moved into the proximity of reed switch inside the stationary stem, the reed switch "snaps" the contact together and closes the electrical circuit. When the magnetic field is moved away from the reed switch, the reed switch does not touch. The circuit is open.

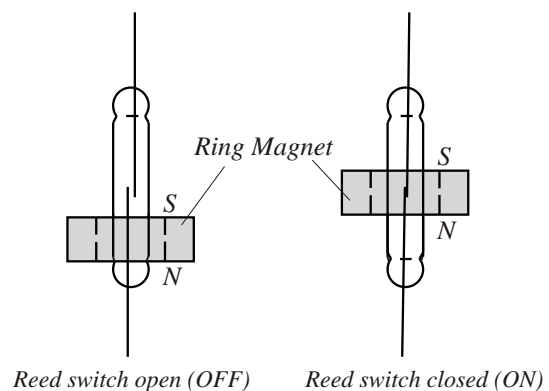

(Fig. 2)

CHEMICAL RESISTANCE

● Excellent ○ Good △ Fair × Corroded

Chemical	Concentration %	Temp		Plastic				Rubber		Stainless	
		°C	°F	PVC	PP	PVDF	PTFE	NBR	304	316	
Ammonia Water NH ₄ OH	10	40	104	●	●	●	●	○			
	10	80	176		○	●	●				
Aque Regia 3HCl+HNO ₃	10	40	104	△	△	●	●				
	10	80	176			●	●				
Benzene C ₆ H ₆	Pure	40	104	×	△	○	●				
		80	176			△	●				
Bleaching Liquor Ca(ClO) ₂	5	40	104	●		●	●				
	5	80	176			●	●				
	20	40	104	●		●	●				
	20	80	176			●	●				
Boric Acid H ₃ BO ₃	Satu	40	104	●	●	●	●	●			
		80	176		●	●	●	○			
Brine		40	104	●	●	●	●	●			
		80	176		●	●	●				
Butadiene CH ₂ =CH=CH=CH ₂	Gas	40	104	●		●	●				
		80	176			●	●				
Butane CH ₃ (C H ₂) ₂ CH ₃	Gas	40	104	●	●	●	●				
		80	176		●	●	●				
Nitric Acid HNO ₃	10	40	104	●	●	●	●	●	●	●	
	10	80	176	×	○	●	●		●	●	
	30	40	104	●	●	●	●		●	●	
	30	80	176	×	○	●	●		●	●	
	50	40	104	○	○	●	●		●	●	
	50	80	176	×	×	○	●				
	70	40	104	○	×	●	●		○	●	
	70	80	176	×		○	●				
	98	40	104			○	○				
	98	80	176				△				
Oxalic Acid HOOC-COOH	20	40	104	●	●	●	●	●		△	
	20	80	176		●	●	●				
	50	40	104	●	●	●	●			△	
	50	80	176		●	●	●				
Phosphoric Acid H ₃ PO ₄	10	40	104	●	●	●	●	●	●	●	
	10	80	176		○	●	●	△	●	●	
	50	40	104	●	●	●	●	●	●	●	
	50	80	176		△	●	●	×	●	●	
	80	40	104	●	●	●	●	○	●	●	
	80	80	176		△	●	●		●	●	
Sodium Hydroxide NaOH	15	40	104	●	●	●	●	●	●	●	
	15	80	176		○	△	●	△	×	×	
	30	40	104	●	●	●	●	●	●	●	
	30	80	176		○	△	●	●	×	×	
	50	40	104	●	●	○	●	●	●	●	
	50	80	176		○	×	●	●	×	×	
	70	40	104	○	○	○	●				
70	80	176		○	×	●					

Chemical	Concentration %	Temp		Plastic				Rubber		Stainless	
		°C	°F	PVC	PP	PVDF	PTFE	NBR	304	316	
Sodium Hypochlorite NaClO	3	40	104	●	○	●	●			△	○
	3	80	176								
	5	40	104	●	○	●	●			△	○
	5	80	176								
	7	40	104	●	△	○	●			×	×
	7	80	176								
	10	40	104	●	△	●	●			×	×
10	80	176									
13	40	104	●	△	●	●			×	×	
13	80	176									
Sulfuric Acid H ₂ SO ₄	10	40	104	●	●	●	●	●	●	●	●
	10	80	176		●	●	●	○	○	○	
	30	40	104	●	●	●	●	●	×	×	
	30	80	176		●	●	●	○	×	×	
	50	40	104	●	●	●	●	○	×	×	
	50	80	176		●	●	●	△	×	×	
	60	40	104	●	●	●	●	●	×	×	
	60	80	176		○	●	●	○	×	×	
	70	40	104	●	●	●	●	○	×	×	
	70	80	176		○	●	●	△	×	×	
	80	40	104	●	●	●	●	●	×	×	
80	80	176		○	●	●	△				
90	40	104	○	●	●	●	△	×	×		
90	80	176		○	●	●	△				
98	40	104	△		●	○		○	○		
98	80	176			△	○					
Toluene C ₆ H ₅ CH ₃		40	104		△	△	●				
		80	176				○				
Chlorine Gas Cl ₂	Wet	40	104	○		●	●				
	Wet	80	176			△	●				
	Dry	40	104	●		●	●				
	Dry	80	176			●	●				
Chromic Acid H ₂ CrO ₄	10	40	104	●		●	●				
	10	80	176			●	●				
	20	40	104	△		●	●				
	20	80	176			●	●				
	40	40	104	△		●	●				
	40	80	176			●	●				
	50	40	104	×		●	●				
50	80	176			△	●					
Hydrochloric Acid HCl	15	40	104	●	●	●	●	○			
	15	80	176		●	●	●				
	25	40	104	●	●	●	●	×			
	25	80	176		●	●	●				
	35	40	104	●	●	●	●	×			
	35	80	176		○	●	●				
	38	40	104	●	●	●	●	×			
	38	80	176		○	●	○				

● Excellent ○ Good △ Fair × Corroded

Chemical	Concentration %	Temp		Plastic				Rubber	Stainless	
		°C	°F	PVC	PP	PVDF	PTFE	NBR	304	316
Citric Acid $C_6H_8O_7$	10	40	104	●	●	●	●	●	●	●
	10	80	176		○	●	●	●		
Gasoline	10	40	104	●		●	●			
	10	80	176			●	●			
Diesel Fuels		40	104			●	●		●	●
		80	176			●	●		●	●
Ethyl Alcohol C_2H_5OH	Pure	40	104	●	●	●	●	●	○	○
		80	176		○	●	●	○		
Formic Acid $HCOOH$	90	40	104	○	○	●	●			
		80	176			●	●			
Hydrofluoric Acid HF	Dilute	40	104	●	○	●	●			
		80	176		○	●	●			
	30	40	104	○	○	●	●			
		80	176	×	○	●	●			
		40	104	△	○	●	●			
		80	176		○	●	●			
		40	104	△	○	●	●			
		80	176		○	●	●			
Hydrogen peroxide H_2O_2	5	40	104	●	●	●	●		○	●
	5	80	176		○	●	●			
	20	40	104	●	●	●	●			
	20	80	176		○	●	●			
	30	40	104	○	○	●	●			
	30	80	176		△	●	●			
	50	40	104	△	×	●	●			
	50	80	176			●	●			
Isopropyl Alcohol $(CH_3)_2CHOH$	Pure	40	104	●	●	●	●		○	
		80	176			●	●			
Kerosene		40	104	●	○	●	●			
		80	176			●	●			
Methyl Alcohol CH_3OH		40	104	○	●	●	●		△	
		80	176		○	●	●			
Methyl Ethyl Ketone $CH_3COCH_2CH_3$		40	104		△		●			
		80	176				●			
Potassium Chromate K_2CrO_4		40	104	●	●	●	●	●		
		80	176		○	●	●	○		

REED SWITCH PROTECTION

■ INDUCTIVE LOADS

When using reed switches for inductive loads such as motors, relay coil, solenoids, etc., the contacts will be subjected to high induced voltages during opening of the contacts (load circuit). Such high induced voltages (transients) may cause damage to the reed switch or significantly reduce its life.

Therefore, protective circuits such as: RC (snubber), varistor or clamping diodes are recommended. (see Fig. 4a, Fig. 4b, Fig. 4c)

- It is prohibited to drive directly solenoid valve, motor or magnetic switch.

$$C = \frac{I^2}{10} \text{ (uF)}$$

$$R = \frac{E}{10I(1 + \frac{E}{50})}$$

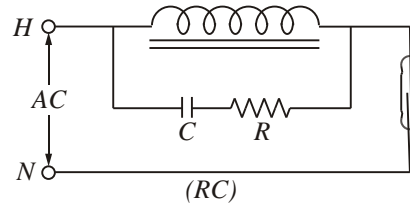

Fig. 4 (a)

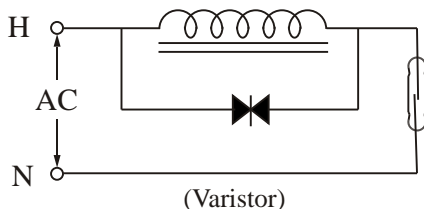

Fig. 4 (b)

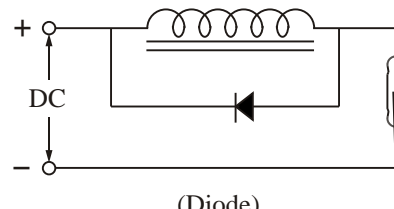

Fig. 4 (c)

■ CAPACITIVE LOADS

When using reed switches for capacitive loads such as capacitors, incandescent lamps or long cables, the contacts will be subjected to high surge (inrush) current.

Therefore, protective circuits such as: surge suppressors or current limiting resistors are recommended. (Fig. 5a, Fig. 5b)

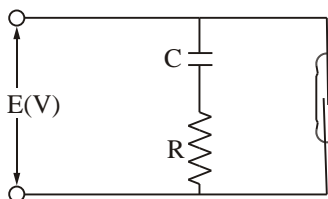

Fig. 5 (a)

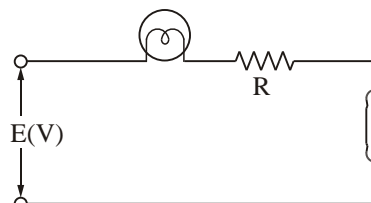
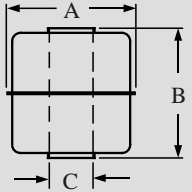
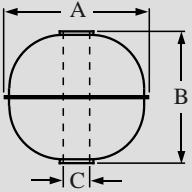
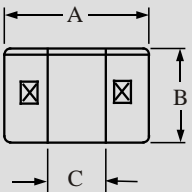
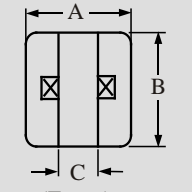
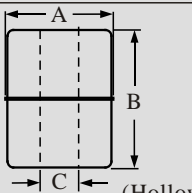

Fig. 5 (b)

FLOAT SPECIFICATIONS

MODEL	TYPE	$\phi A \times B \times \phi C$	S.G.	Max. Pressure (kg/cm ²)	Weight (g)	Material/Color	Max. Temp. (°C)
	S1	28 × 28 × 9.5	E>0.7	10	8	SUS 304 / 316L	200
	S3	45 × 55 × 15	E>0.65	12	37.6	SUS 316	200
	S6	75 × 108 × 20	E>0.5	10	165	SUS 304	200
	S2	41 × 38 × 11	E>0.7	35	19.5	SUS 316	200
	S4	52 × 52 × 15	E>0.55	30	33.4	SUS 316	200
	S5	75 × 73 × 19	E>0.65	30	102.4	SUS 304	200
	S7	30 × 28 × 9.5	E>0.82	30	8	SUS 304 / 316L	200
	S8	100 × 100 × 20	E>0.5	15	249.7	SUS 304	200
	S9	150 × 150 × 30	E>0.45	15	534	SUS 304	200
	S11	28 × 32 × 9.5	E>0.82	30	8.1	SUS 304	200
 <p>(Hollow)</p>	P1	25 × 15 × 10	E>0.65	4	3.5	PP / white black	80
	P2	25 × 25 × 10	E>0.55	4	5	PP / white black	80
	P3	48 × 45 × 18.5	E>0.6	5	35.5	PP / black	80
	P4	20 × 25 × 10	E>0.7	4	3.7	PP / black	80
	P5	20 × 20 × 8.1	E>0.75	4	4	PP / black	80
	P8	18.2 × 15.3 × 7.2	E>0.8	4	1.82	PP / black	80
 <p>(Foam)</p>	Q6	20 × 20 × 7.5	E>0.75	ATM	3.5	PP / white	80
	Q7	25 × 25 × 8.8	E>0.7	ATM	6.7	PP / white	80
	N1	25 × 15 × 10	E>0.5	ATM	2.7	NBR / black	100
	N2	18.5 × 26 × 10	E>0.7	ATM	3.3	NBR / black	100
	N3	19 × 20 × 10	E>0.55	ATM	2.4	NBR / black	100
	N4	17.5 × 25 × 10	E>0.65	ATM	2.5	NBR / black	100
	N5	30 × 45 × 12.8	E>0.5	ATM	11.5	NBR / black	100
 <p>(Hollow)</p>	F2	42 × 44 × 14	E>0.63	5	18.5	PP	80
	F3	45 × 45 × 20	E>0.65	5	35.7	PP	80
	F4	48 × 62 × 18	E>0.8	5	65.3	PVDF	120

METAL SINGLE SWITCH TYPES

► FD MH50/ 56

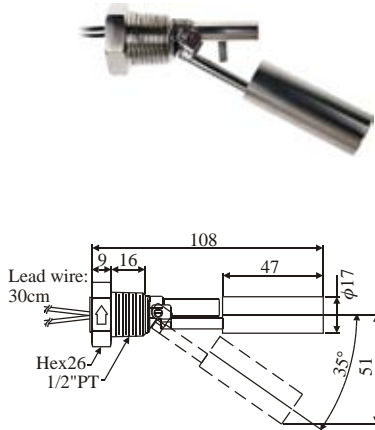

► FD MH50A /56A

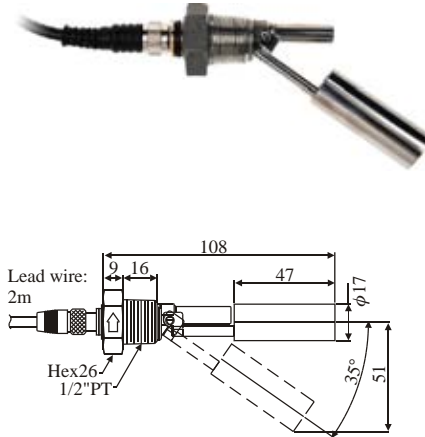

► FD MH50C /56C

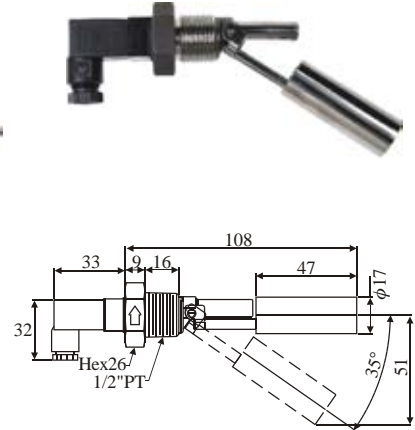

► FD MH60/ 66

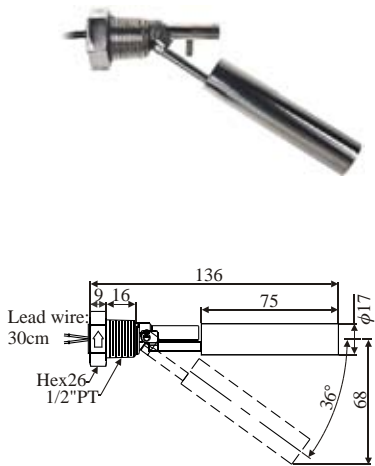

► FD MH60A/ 66A

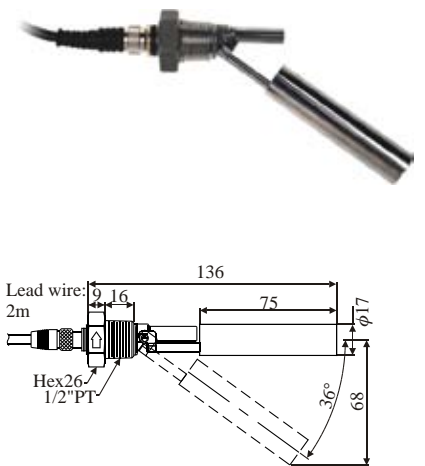

► FD MH60C/ 66C

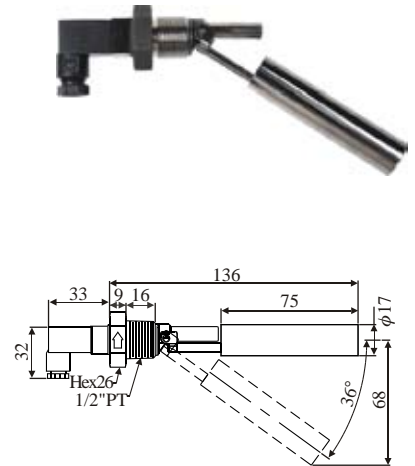

■ SPECIFICATIONS

Type	Material	Switching Capacity Max.	Switching Voltage Max.	Switching Current Max.	Carry Current Max.	Lead Wire	Max. Pressure	Operating Temp.	Suitable Sp. Gr.
FDMH50/56 FDMH60/66	SUS 304 SUS 316L	50W/SPST	240Vac 200Vdc	0.5A	1A	XLPE or TEFLON	5 kg/cm ²	-20~120°C (Max.200°C)	FDMH5:0.92 FDMH6:0.75
FDMH50A/56A FDMH60A/66A	SUS 304 SUS 316L	50W/SPST	240Vac 200Vdc	0.5A	1A	XLPE or TEFLON	5 kg/cm ²	80°C	FDMH5:0.92 FDMH6:0.75
FDMH50C/56C FDMH60C/66C	SUS 304 SUS 316L	50W/SPST	240Vac 200Vdc	0.5A	1A	XLPE or TEFLON	5 kg/cm ²	-20~120°C	FDMH5:0.92 FDMH6:0.75

ORDER INFORMATION FOR METAL SINGLE SWITCH TYPES

FDMH **5** **0** **A** **B** **R** (**0** **5** **F**)

Type _____

5: ϕ 17x47L (SG: 0.92) **6:** ϕ 17x75L (SG: 0.75)

Material _____

0: SUS304 **6:** SUS316L

Connection _____

– : without, **A:** ASI, **C:** DIN

Connecting Type _____

BR: 1/2"PF, **BQ:** 1/2"PT, **BU:** 1/2"NPT, **BT:** 1/2"BSP

Lead wire Length (Unit=100mm) _____

05: 500mm (below 500mm) ※ 500mm per Unit
10: 1000mm (501~1000mm) ※ 300mm (Standard length)
15: 1500mm (1001~1500mm)
 ⋮

Material of Lead wire _____

F: SILICON (200°C) AWG24 X ϕ 4
T: TEFLON (200°C) AWG24
X: XLPE (125°C) AWG22 (Standard)
 ※ Material of Wetted parts "SUS304" ◦

METAL TYPES

► FD 30□1/ FD 35□1

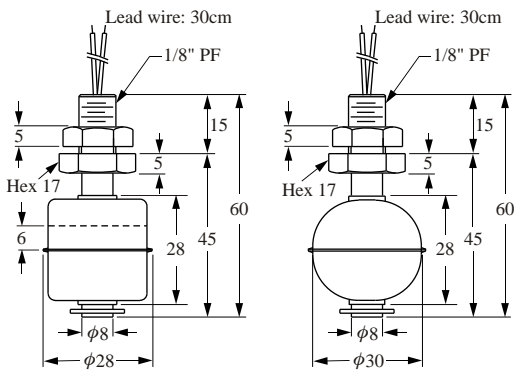
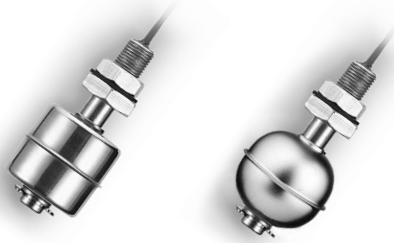

Washer: NBR
Drill hole $\phi 10\text{mm}$

► FD 40□1

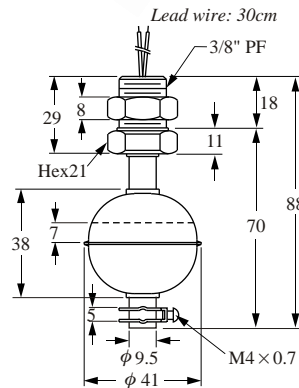

Washer: NBR
Drill hole $\phi 17\text{mm}$

► FD 45□1

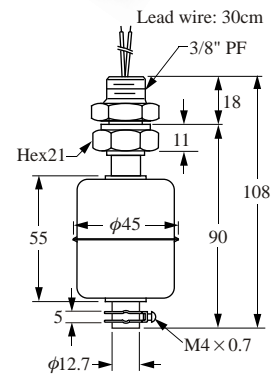

Washer: NBR
Drill hole $\phi 17\text{mm}$

► FD 30□2

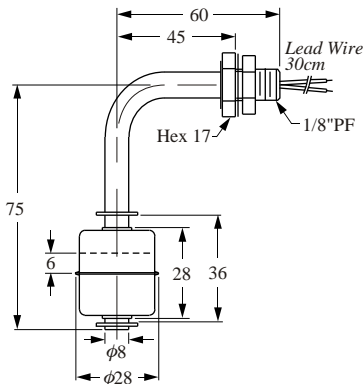

Washer: NBR
Drill hole $\phi 10\text{mm}$

► FD 40□2

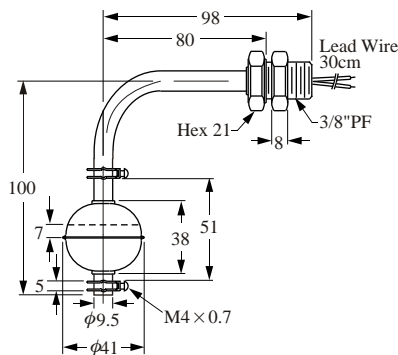

Washer: NBR
Drill hole $\phi 17\text{mm}$

► FD 45□2

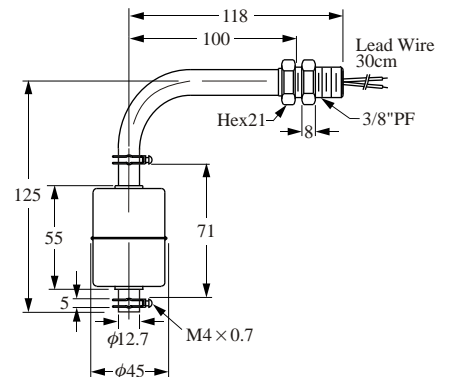

Washer: NBR
Drill hole $\phi 17\text{mm}$

METAL TYPES

► FD 50□1

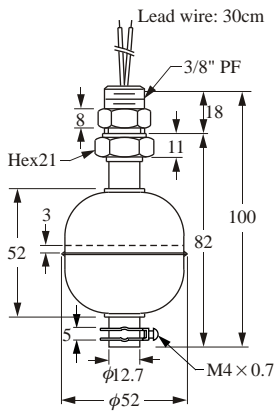

Washer: NBR
Drill hole φ17mm



► FD 50□2

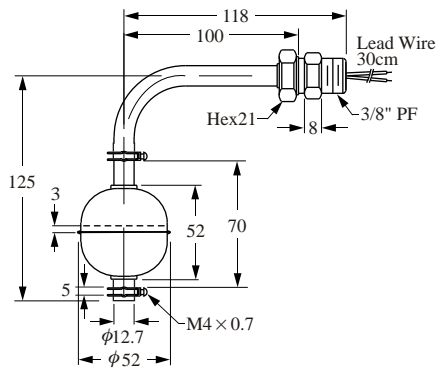

Washer: NBR
Drill hole φ17mm



► FD 75□1

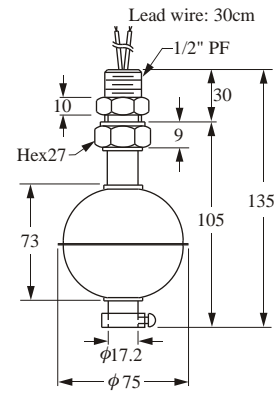

Washer: NBR
Drill hole φ21mm



■ SPECIFICATIONS

Description	Type	FD30□1D	FD40□1D	FD45□1D	FD50□1D	FD75□1G	FD10□1G
		FD30□2D	FD40□2D	FD45□2D	FD50□2D		
Switching Capacity Max.		50W SPST	50W SPST	50W SPST	50W SPST	60W SPDT	
Switching Voltage Max.		240Vac/200Vdc				220Vac	
Switching Current Max. (A)		0.5A	0.5A	0.5A	0.5A	2A	
Carry Current Max. (A)		1A	1A	1A	1A	3A	
Lead Wire		XLPE (UL3266, AWG22)					
Reversible Switch Action		YES / below 80°C, NO / UP 80°C				NO	NO
Max. Pressure (Kg/cm ²)		10	30	12	30	30	10
Operating Temperature		-20~120°C (OPTION 200°C)					
Material		Stainless Steel SUS304, 316					
Suitable Specific Gravity		0.8	0.7	0.65	0.55	0.55	0.5

PLASTIC OH TYPES

► FCH11QD

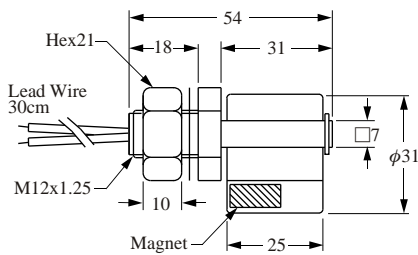
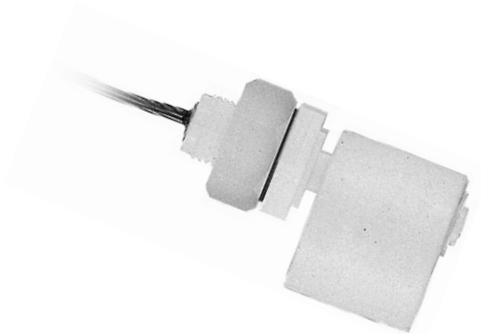

Washer: NBR

■ Installation / N.C./ N.O. Action Position

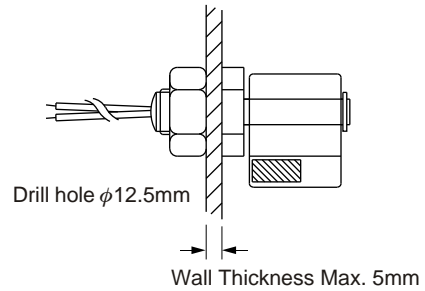

Normally open
N.O.

Normally closed
N.C.

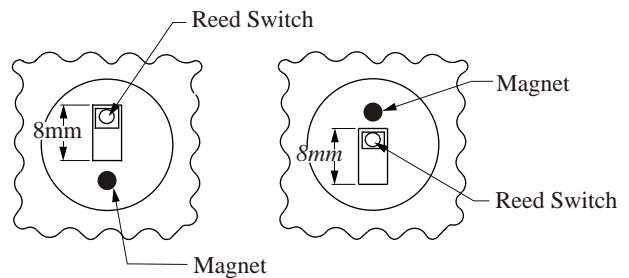

- All the products in this range come with the UL E161587 approval.
- All the products in this range are designed to be mounted on the side.
- For the specific gravity of water is used as a reference point in calculating specific gravity.

■ SPECIFICATIONS

Description	Type	FCH11QD	FCH21PD FCH31PD	FCH23FD FCH33FD	FCH24YD FCH34YD	FCH25GD FCH35GD
Switching Capacity Max.		50W SPST				
Switching Voltage Max.		240VAC / 200Vdc				
Switching Current Max. (A)		0.5A				
Carry Current Max. (A)		1A				
Lead Wire		PVC AWG22	XLPE AWG22			
Max. Pressure (Kg/cm ²)		ATM	4 kg/cm ²	2 kg/cm ²		
Operating Temperature		-20~80°C			-20~120°C	
Material		PP		PVDF	Nylon	Polysuphone
Suitable Specific Gravity		0.78	0.75	0.85	0.8	0.85
Weight		25 g	H21: 22 g H31: 21 g	25 g	23 g	25.4 g

PLASTIC OH TYPES

► FC H21PD / H31PD



- For models FCH2 and FCH3, three different types of material are available PP, Nylon, and PVDF.
- The special lead wire or cable can be supplied according to the requirement of the customer.
- The customer can select the type of reed switch which they requires.
- For specifications of the standard design see catalog (page 10).
- OEM customers are welcome.

■ Optional FC H21PDO(Round)

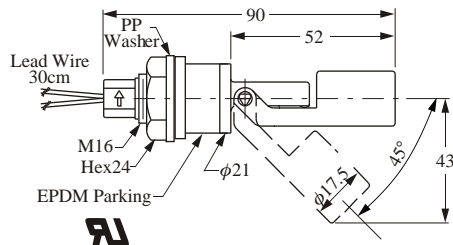

■ Installation / N.C. / N.O. Action Position

[External mounting]

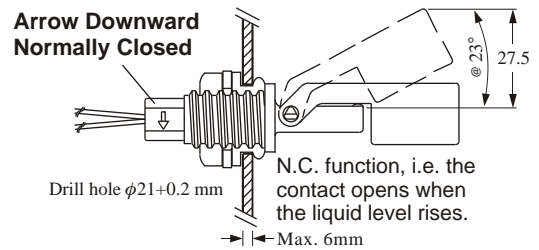

■ Standard FC H21PDD (Hexagon)

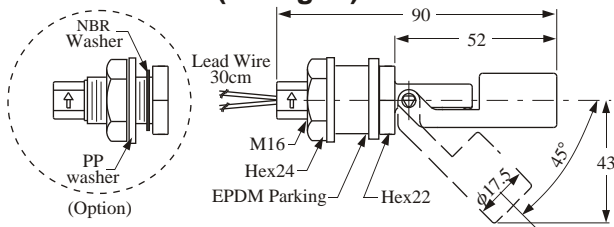

[Internal mounting]

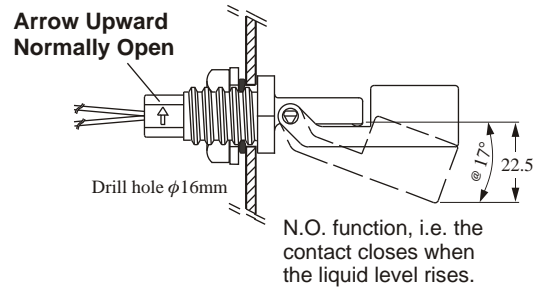

■ FC H31PD

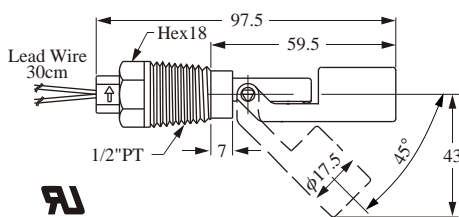

[External mounting]

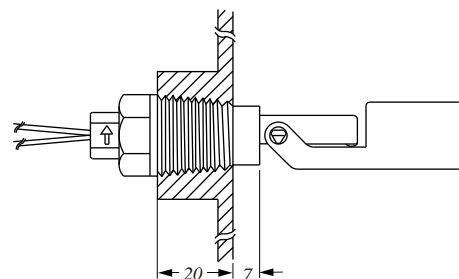

PLASTIC OH TYPES

► FC H41PD / H51PD

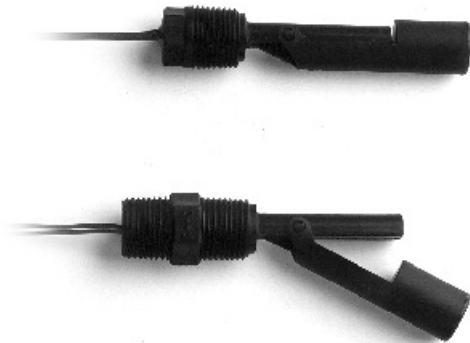

■ Installation / N.C. / N.O. Action Position

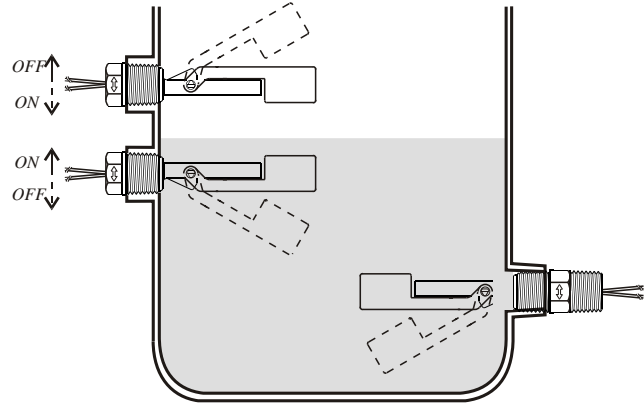

■ FC H41PD

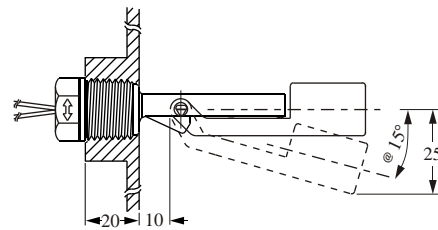
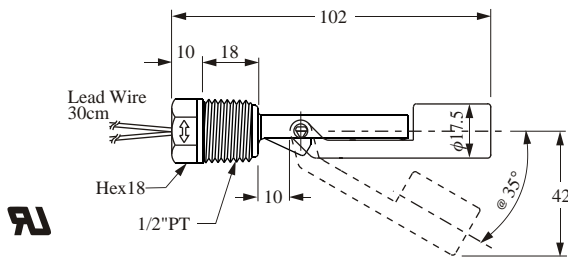

N.O. function, i.e. the contact closes when the liquid level rises.

■ FC H51PD

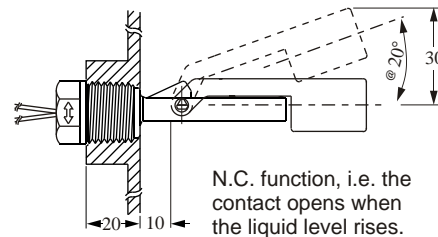
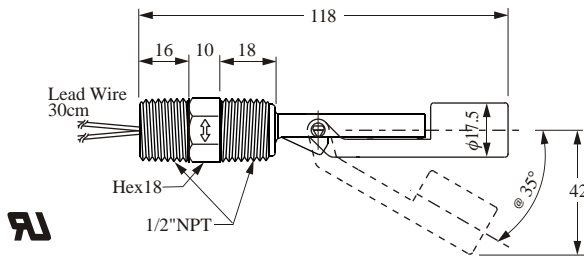

N.C. function, i.e. the contact opens when the liquid level rises.

■ FC H61PD

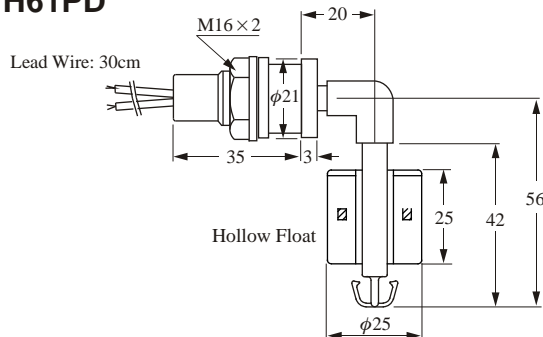

■ SPECIFICATIONS

Type	Material	Switching Capacity Max.	Switching Voltage Max.	Switching Current Max.	Carry Current Max.	Lead Wire	Max. Pressure	Operating Temp.	Suitable Sp. Gr.	Weight
FCH41PD	PP	50W/SPST	240Vac 200Vdc	0.5A	1A	XLPE	4 kg/cm ²	-20~80°C	0.65	20g
FCH51PD									0.65	25g
FCH61PD									0.7	31g

PLASTIC OV TYPES

▶ FC V11QF

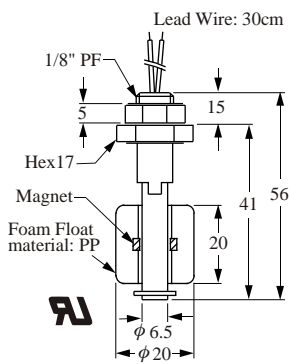

Washer: NBR
Drill hole φ10mm

▶ FC V21QD

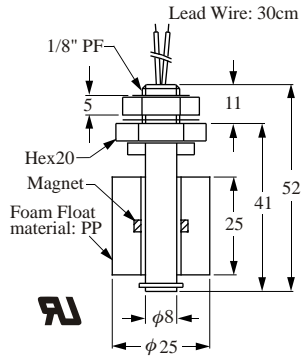

Washer: NBR
Drill hole φ10mm

▶ FC V31PD

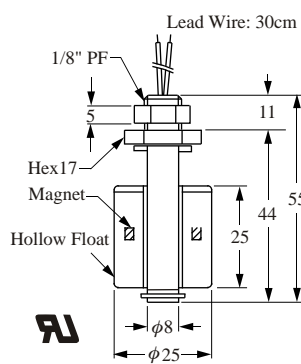

O-ring: VITON
Drill hole φ10mm

▶ FC V33FD, 34YD, 35GD

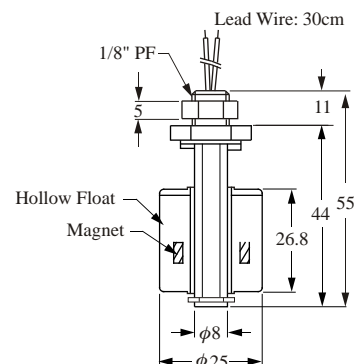

O-ring: VITON
Drill hole φ10mm

■ SPECIFICATIONS

Description \ Type	FC V11QF	FC V21QD	FC V31PD	FC V33FD	FC V34YD	FC V35GD
Switching Capacity Max.	10W SPST	50W SPST	50W SPST			
Switching Voltage Max.	125Vac	240Vac / 200Vdc	240Vac / 200Vdc			
Switching Current Max. (A)	0.5A		0.5A			
Carry Current Max. (A)	1A		1A			
Lead Wire	UL 1007 AWG22 PVC		UL 1007 AWG22 PVC	XLPE AWG22		
Reversible Switch Action	NO	YES/ 80°C down	YES/ 80°C down			
Max. Pressure (Kg/cm ²)	ATM		4 kg/cm ²	2 kg/cm ²		
Operating Temperature	-20~80°C		-20~80°C	-20~120°C		
Material	PP		PP	PVDF	Nylon	Polysuphone
Suitable Specific Gravity	0.7		0.7	0.85	0.8	0.75
Weight (g)	12 g	18 g	12.8 g	18 g	15 g	18 g

PLASTIC OV TYPES

▶ FC V11NF

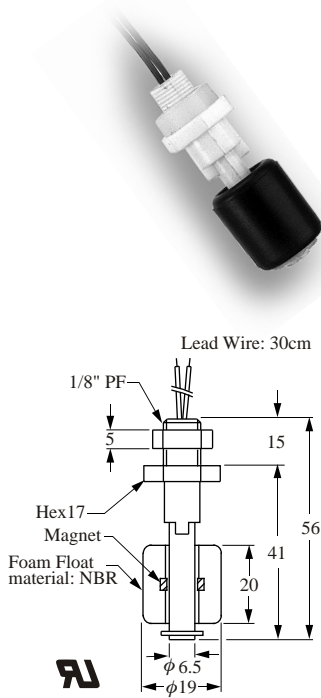

Washer: NBR
Drill hole $\phi 10\text{mm}$

▶ FC V41PD, V41QD

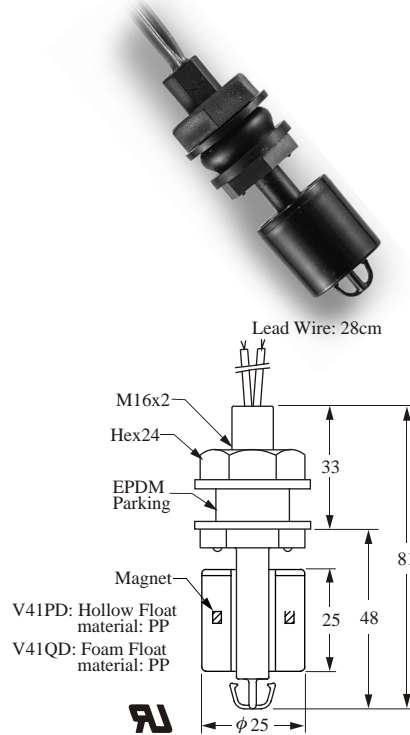

Washer: NBR
Drill hole $\phi 16\text{mm}$

▶ FC V61PF, V61NF

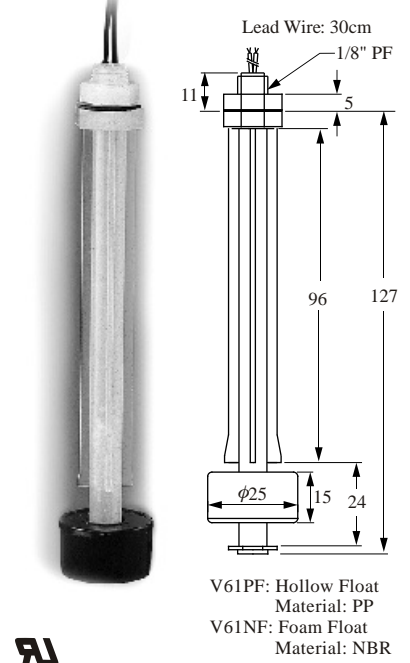

Washer: NBR
Drill hole $\phi 10\text{mm}$

▶ FC V81PD

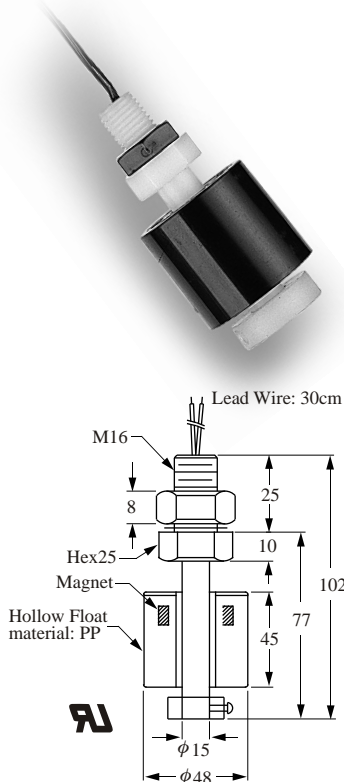

Washer: NBR
Drill hole $\phi 16\text{mm}$

▶ FC V41ND

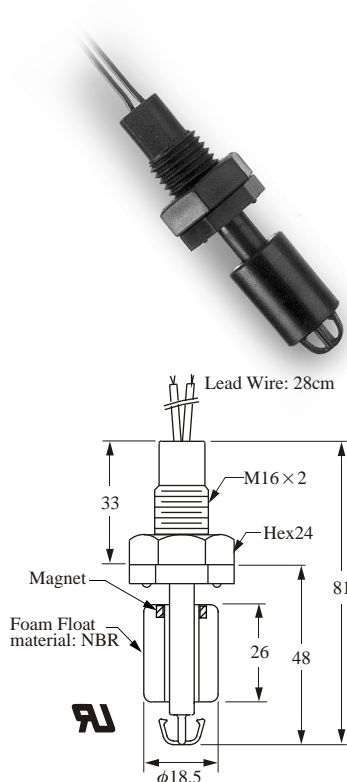

Washer: NBR
Drill hole $\phi 16\text{mm}$

▶ FC V51PD

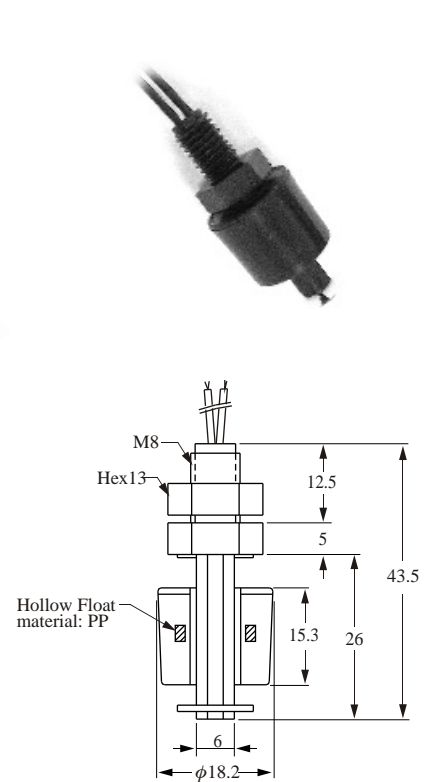

O-Ring: VITON
Drill hole $\phi 8.5\text{mm}$

PLASTIC OV TYPES

■ SPECIFICATIONS

Description \ Type	FC V11NF	FC V61PF FC V61NF	FC V41PD FC V41QD	FC V81PD	FC V41ND	FC V51PD
Switching Capacity Max.	10W SPST		50W SPST			
Switching Voltage Max.	125Vac (Break Down 250Vac)		240Vac / 200Vdc			
Switching Current Max. (A)	0.5A					
Carry Current Max. (A)	1A					
Lead Wire	XLPE AWG22	UL 1007 AWG22 PVC				
Reversible Switch Action	NO	NO	YES	NO	NO	NO
Max. Pressure (kg/cm ²)	ATM	V61P: 4kg/cm ² V61N: ATM	V41P: 4kg/cm ² V41Q: ATM	4 kg/cm ²	ATM	4 kg/cm ²
Operating Temperature	-20~80°C					-20 ~100°C
Material	PP (except V11N, V61N, V41N: NBR float)					
Suitable Specific Gravity	0.8	0.65 0.5	0.55 0.7	0.6	0.8	0.8
Weight (g)	11 g	16 g	23 g	180 g	17 g	8.2 g

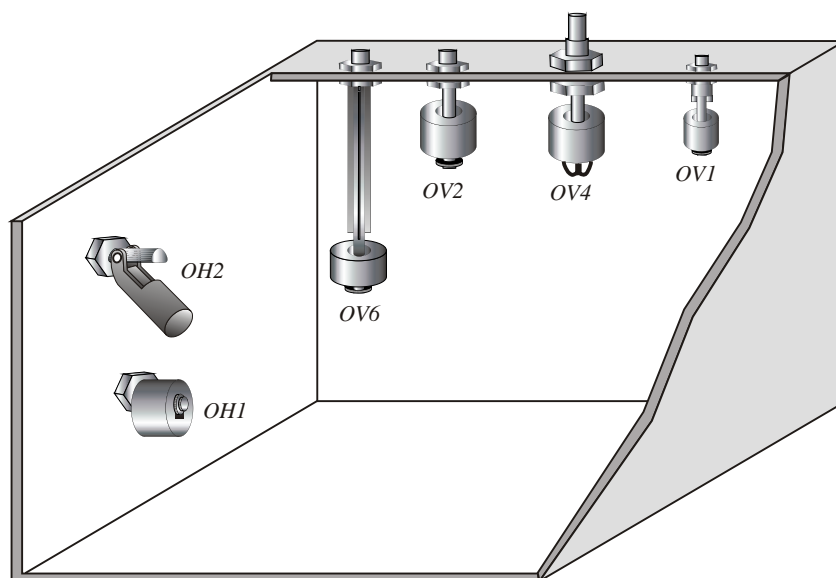

ORDER INFORMATION FOR PLASTIC OH/OV TYPES

FC **V2** **3** **F** **D** **A** (**05** **P**)

Order No./ Model _____

FC H1~H6: RF-OH Side Mounting
FC V1~V9: RF-OV Top or bottom Mounting

Material of Wetted parts _____

1 : PP 5 : Polysuphone
 3 : PVDF 6 : PPS
 4 : Nylon

Material of Float _____

F : PVDF P : PP (hollow) K : PPS
 N : NBR Q : PP (foam)
 G : Polysuphone Y : Nylon
 (Unsuitable for use in water application for long term)

Switching Capacity Max. _____

D : 50W 240Vac /200Vdc SPST 
 F : 10W 125Vac SPST
 K : 20W 150Vac/200Vdc SPDT

Contact Form _____

A : Normally Open (N.O.) SPST
 B : Normally Close (N.C.) SPST
 C : 1AB SPDT
 D : NC Reversible
 E : NO Reversible

Lead wire Length (Unit=100mm) _____

05: 500mm (below 500mm) ※ 500mm per Unit
 10: 1000mm (501~1000) ※ 300mm (Standard length)
 15: 1500mm (1001~1500)
 ⋮

Material of Lead wire _____

B : PVC (80°C) ---- AWG24
 C : PVC cable (80°C) ---- AWG22 X φ4
 D : XLPVC (105°C) ---- AWG24
 F : SILICON cable (200°C) ---- AWG24X φ4
 P : PVC (80°C) ---- AWG22
 T : TEFLON (200°C) ---- AWG24
 X : XLPE (125°C) ---- AWG22
 S : Others

※ "A" (Normal Open) contact form is our standard specified switch activation, others contact form and target lead wire length subject to above data, except of above, please refer pages 6, 7, 9, 10 and 12.

PLASTIC SPECIAL TYPES

▶ FC PV1

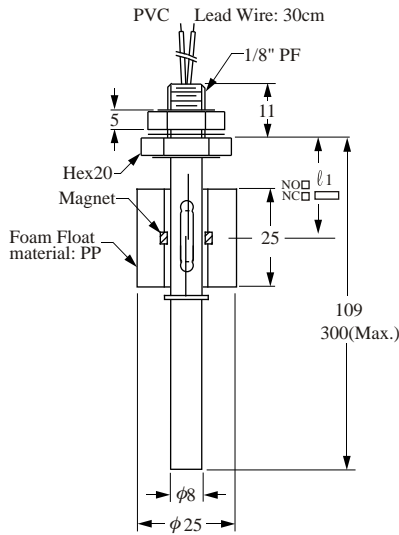

O-Ring: VITON

▶ FC PV2

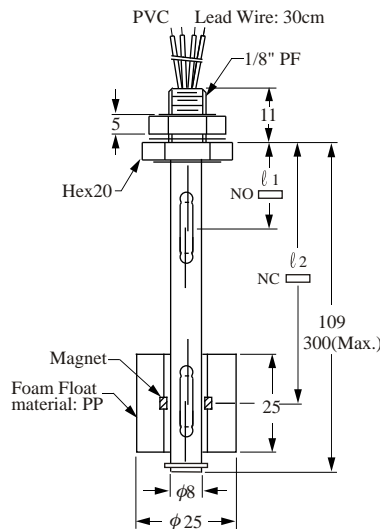
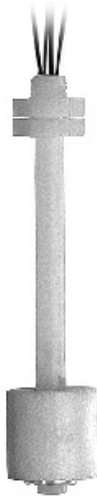

O-Ring: VITON

▶ FC PV3

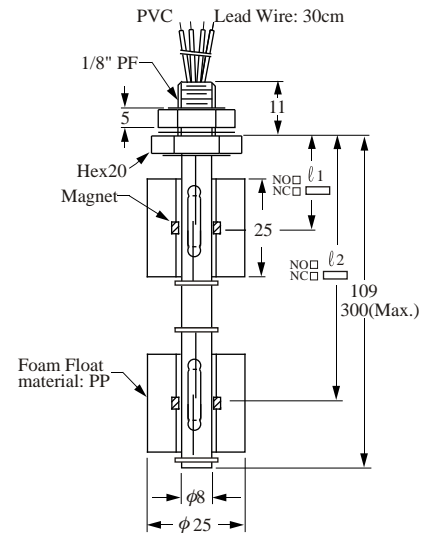

O-Ring: VITON

● NOTE: Float material can be optional.

Above items are done by custom-built when the standard specification is unable to be coped with their unique demand. There are with below special benefits:

- FCPV1 One float for one level activation switch location by custom-order.
- FCPV2 One float with 2 reed switches, applicable for high / low two level activation, especial design by one float to drive two contacts activation.
- FCPV3 Two floats drive with two independent reed switches, the compared difference with FCPV2 base on below character : Each one float unit can be performed by N.O. or N.C. level activation as per customer's option.

ORDER INFORMATION FOR PLASTIC SPECIAL TYPE

FC **PV1** **2** **D** **A** (**05** **P**)

Order No./ Model _____

PV1: RF-PV1 Vertical Mounting, Single Float Single Switch

PV2: RF-PV2 Vertical Mounting, Single Float Dual Switch

PV3: RF-PV3 Vertical Mounting, Dual Float Dual Switch

Material of Wetted parts _____

1 : PP; Lead wire---PVC---Temp. 80°C

2 : NBR (only float); Lead wire---PVC---Temp. 60°C
 Lead wire---XLPE---Temp. 100°C

3 : PVDF; Lead wire---XLPE---Temp. 125°C

4 : Nylon; Lead wire---XLPE---Temp. 125°C
 (Unsuitable for use in water application for long term)

Switching Capacity Max. _____

D: 50W 240Vac /200Vdc SPST 

F : 10W 125Vac SPST

K: 20W 150Vac/200Vdc SPDT

Contact Form _____

A: Normally Open (N.O.) SPST

B: Normally Close (N.C.) SPST

C: SPDT

F: 1 float 2 points.

H: 1-N.O.,1-N.C.(2 floats)

Lead wire Length (Unit=100mm) _____

05: 500mm (below 500mm) ※ 500mm per Unit

10: 1000mm (501~1000mm) ※ 300mm (Standard length)

15: 1500mm (1001~1500mm)

⋮

Material of Lead wire _____

C: PVC cable (80°C) ---- AWG22 X ϕ 4

P: PVC (80°C) ---- AWG22 (Standard)

X: XLPE (125°C) ---- AWG22

ORDER INFORMATION FOR METAL TYPE

FD **30** **6** **2** **D** **A** **(10)** **H)**

Order No./ Model

- 10 Float : ϕ 75x108, Screw : 1/2"PF
- 30 Float : ϕ 28x28, Screw : 1/8"PF
- 31 Float : ϕ 28x28, Screw : 1/8"NPT
- 35 Float : ϕ 30x28, Screw : 1/8"PF
- 36 Float : ϕ 30x28, Screw : 1/8"NPT
- 40 Float : ϕ 41x38, Screw : 3/8"PF
- 45 Float : ϕ 45x55, Screw : 3/8"PF
- 50 Float : ϕ 52x52, Screw : 3/8"PF
- 75 Float : ϕ 75x70, Screw : 1/2"PF

Material of Wetted parts

- 0 : SUS304
- 6 : SUS316

Mounting

- 1 : Top or Bottom Mounting
- 2 : Side Mounting

Switching Capacity Max.

- D: 50W 240Vac /200Vdc SPST 
- F: 10W 125Vac SPST
- G: 60W 220Vac SPDT (only use for tube $\geq \phi$ 12.7)
- S: Others

Contact Form

- A: Normal Open (N.O.) SPST ※ High Temp only available for A or B Type
- B: Normal Close (N.C.) SPST
- C: 1C SPDT
- D: N.C. Reversible
- E: N.O. Reversible

Lead wire Length (Unit=100mm)

- 05: 500mm (below 500mm) ※ 500mm per Unit
- 10: 1000mm (501~1000mm) ※ 300mm (Standard length)
- 15: 1500mm (1001~1500mm)

⋮

Material of Lead wire

- B: PVC cable (80°C) ---- AWG24
- C: PVC cable (80°C) ---- AWG22 X ϕ 4 ※ ϕ 8 Stem is not suitable.
- D: XLPVC (105°C) ---- AWG22
- F: SILICON cable (200°C) ---- AWG24X ϕ 4
- P: PVC (80°C) ---- AWG22
- T: TEFLON (200°C) ---- AWG24
- X: XLPE (125°C) ---- AWG22 (Standard)

High Temp. (200°C)

METAL SPECIAL TYPES

Below items are custom-built subject to special application place and existed equipment facilities. Their unique characters as follow:

- Any size measuring range, but $\phi 8\text{mm}$ stem Max. 500mm.
- Customized mounting thread specification are acceptable.
- Single or multiple contact form (point) are workable.
- Switch activation N.O. or N.C. are available.

► FDSA□11

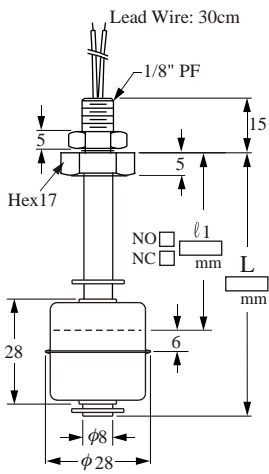

Washer: NBR

► FDSB□11

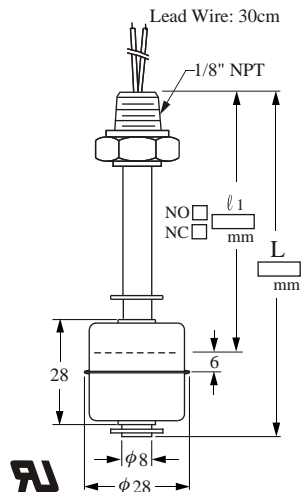

Washer: NBR

► FDSC□11

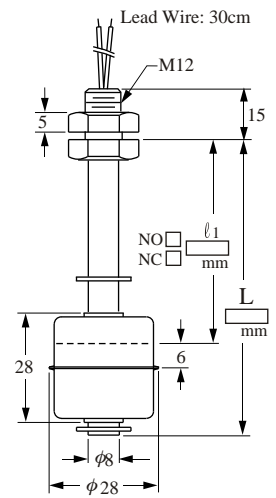

Washer: NBR

► FDSA□12

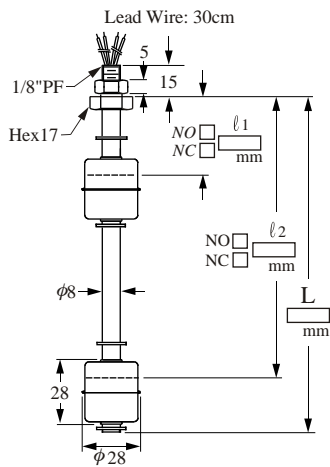

Washer: NBR

► FDSA□21

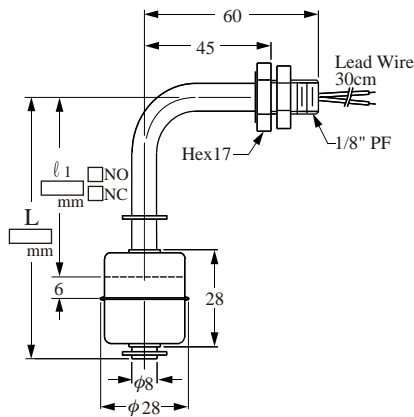

Washer: NBR

► FDSA□22

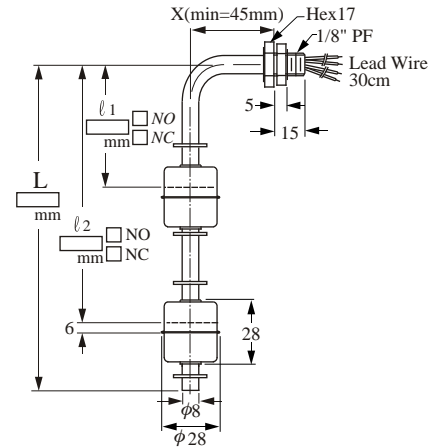

Washer: NBR

METAL SPECIAL TYPES

Below items are custom-built subject to special application place and existed equipment facilities. Their unique characters as follow:

- Any size measuring range.
- Customized mounting thread specification are acceptable.
- Single or multiple contact form (point) are workable.
- Switch activation N.O. or N.C. are available.

► FDSD□11

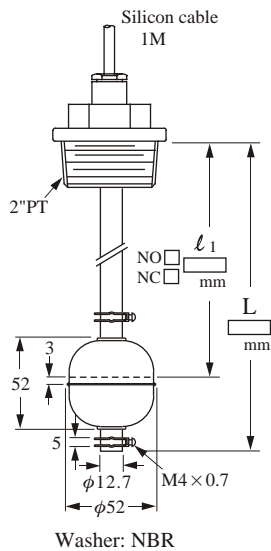

► FDSE□11

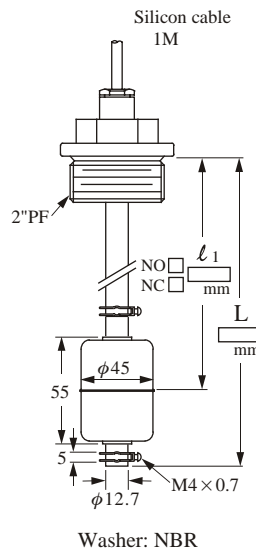

► FDSF□11

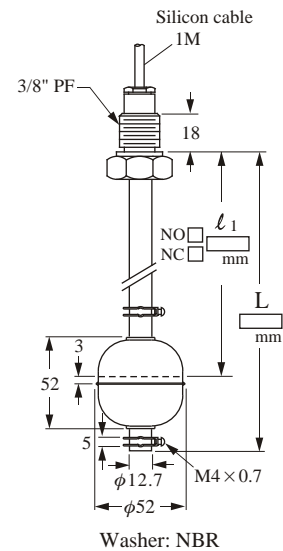

► FD4503D

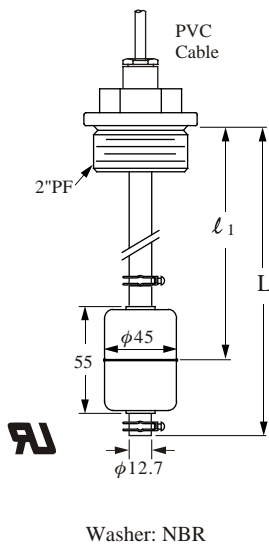

► FD5003G

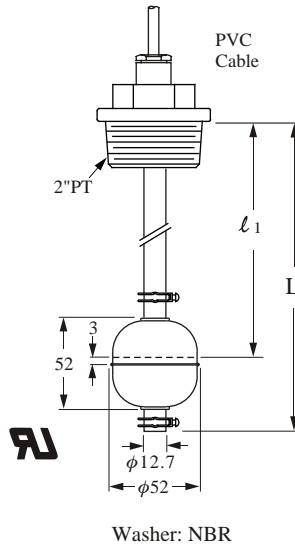

► FD7503G

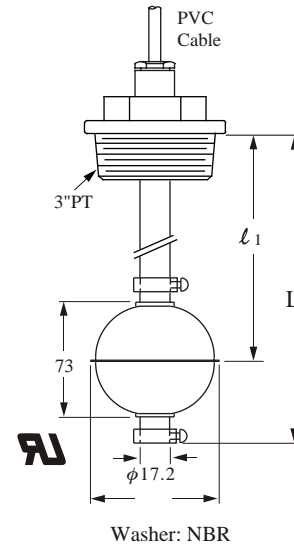

ORDER INFORMATION FOR METAL SPECIAL TYPE

FD **S** **A** **6** **1** **2** **D** **A** **05**

Type _____

- FDSA** Float : **RF-SA** ϕ 28x28, Screw : 1/8"PF
- FDSB** Float : **RF-SB** ϕ 28x28, Screw : 1/8"NPT
- FDSC** Float : **RF-SC** ϕ 28x28, Screw : M12
- FSD** Float : **RF-SD** ϕ 52x52, Screw : 2"PT
- FDSE** Float : **RF-SE** ϕ 45x55, Screw : 2"PF
- FDSF** Float : **RF-SF** ϕ 52x52, Screw : 3/8"PF

Material of Wetted parts _____

- 0** : SUS304
- 6** : SUS316

Mounting _____

- 1** : Top or Bottom Mourting
- 2** : Side Mounting

Float Number _____

1~4 floats

Switching Capacity Max. _____

- D**: 50W 240Vac /200Vdc, SPST
- G**: 60W 220Vac, SPDT (only use for tube $\geq \phi$ 12.7)
- K**: 20W 150Vac /200Vdc, SPDT

Contact Form _____

- A**: Normal Open (N.O.) SPST **F**: 1 float 2 points
- B**: Normal Close (N.C.) SPST **H**: 1-N.O.,1-N.C.(2 floats)
- C**: 1AB SPDT

Lead wire Length (Unit=100mm) _____

- 03**: 300mm (SA, SB, SC, Standard length) ※ 500mm per Unit
- 05**: 500mm (below 500mm)
- 10**: 1000mm (SD, SE, SF, Standard length)
- 15**: 1500mm (1001~1500mm)

Material of Lead wire _____

- C**: PVC cable (80°C) ---- AWG22 X 2C X ϕ 4
 - F**: SILICON cable (200°C) ---- AWG24 X 2C X ϕ 4
 - P**: PVC (80°C) ---- AWG22
 - T**: TEFLON (200°C) ---- AWG24
 - X**: XLPE (125°C) ---- AWG22 (Standard)
- } For SA, SB, SC Type

TYPICAL WIRING DIAGRAMS

* AUTO SUPPLY CASE:
SINGLE FLOAT DUAL SWITCHES

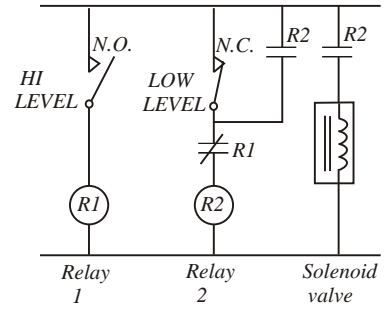
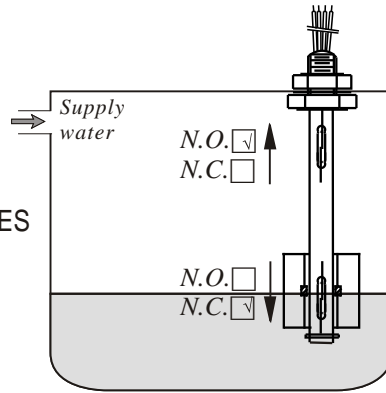

* AUTO DRAIN CASE:
SINGLE FLOAT DUAL SWITCHES

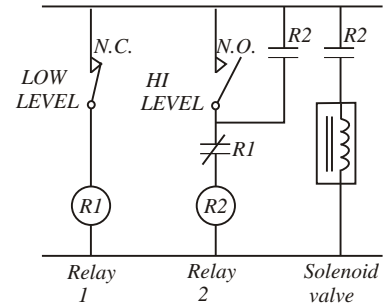
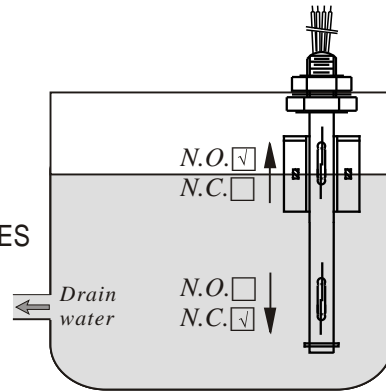

* AUTO SUPPLY CASE:
DUAL FLOATS DUAL SWITCHES

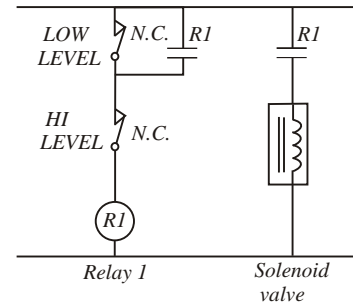
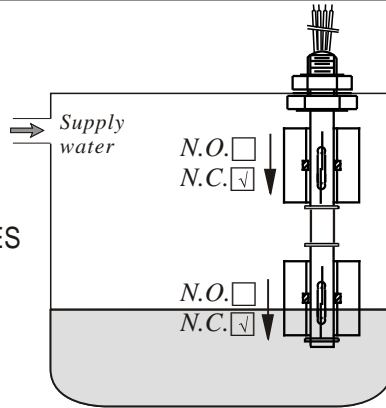

* AUTO DRAIN CASE:
DUAL FLOATS DUAL SWITCHES

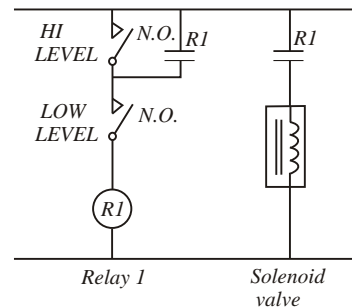
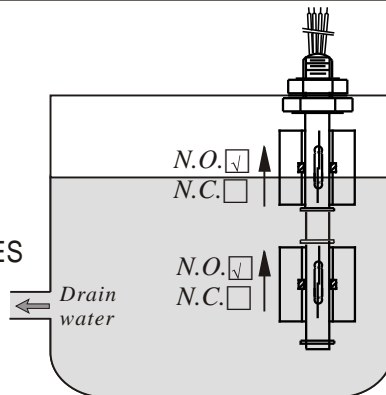

EXAMPLES-OF-TANK-MOUNTING

- [FC/FD] Mini Float/Magnetic Float Level Switch
- [FG] Magnetic Float Level Transmitter
- [FF] Side Mounting Float Switch
- [FA/FB] Cable Float Level Switch
- [SP] Thermal Dispersion Flow Switch
- [SF] Paddle Flow Switch
- [SD] Optical Level Switch
- [SE] Rotary Paddle Level Switch
- [SA] Capacitance Level Switch
- [EC] Pressure Level Transmitter
- [LR] Loop Power Indicator
- [SC] Vibrating Probe Level Switch
- [SC] Tuning Fork Level Switch
- [EB] RF-Capacitance Level Transmitter
- [SB] RF-Capacitance / Admittance Level Switch
- [EG] Magnetostrictive Level Transmitter
- [EF] By-Pass Level Transmitter
- [MEF] Mini By-Pass Level Transmitter
- [EA] Ultrasonic Level Transmitter
- [JFR] FMCW Radar Level Transmitter
- [EE] Electromechanical Level Measuring System
- [ED] Speed Monitor
- [SRT/SRS] Conveyer Belt Misalignment Switch & Safety Cable Pull Switch
- [PB/PM] Microprocessor Based Bargraphic Display Scaling Meter
- [BRD/AE] Valve and Controller for Dust Collector System
- [BAS/BAH/BVP] Air Hammer
- [BVK/BVR/BVT] Pneumatic Vibrator

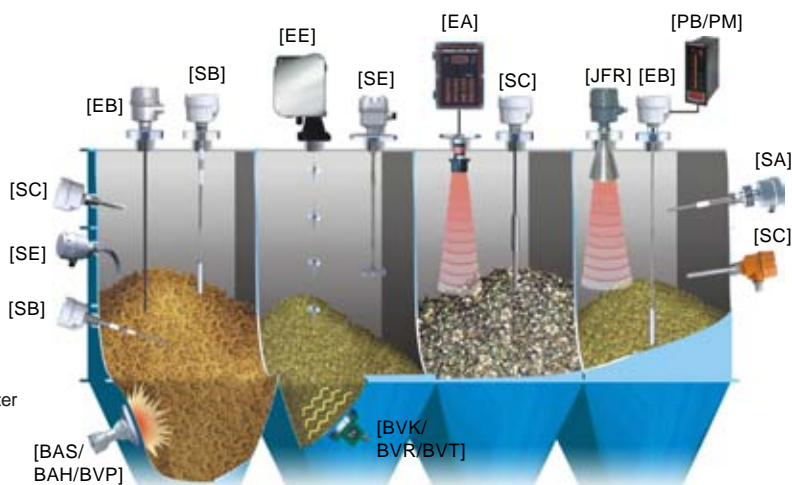
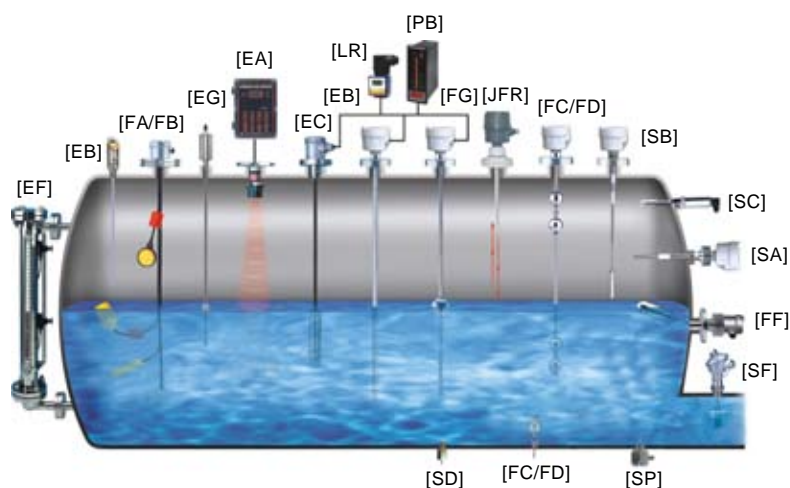

FineTek Co., Ltd.

No.16, Tzuchiang St., Tucheng Industrial Park, New Taipei City 236, Taiwan
 TEL: +886-2-2269-6789 FAX: +886-2-2268-6682
 Email: info@fine-tek.com http://www.fine-tek.com

Fine automation (ShangHai) Co., Ltd.

No.451 DuHui Rd, MinHang District, Shanghai, China 201109
 TEL: +86-21-6490-7260 FAX: +86-21-6490-7276
 Email: info.sh@fine-tek.com

FineTek Pte Ltd.

No. 11 Kaki Bukit Road 1, #04-01 Eunos
 Technolink 415939, Singapore
 TEL: +65-6452-6340 FAX: +65-6734-1878
 Email: info.sg@fine-tek.com

FineTeK GmbH

Frankfurter Str. 62, OG D-65428 Ruesselsehim, Germany
 TEL: +49-(0)6142-17608-0 FAX: +49-(0)6142-17608-20
 E-Mail: info@fine-tek.de



Distributor:



Garma Electrónica, S.L.
 CIF: B-20178372
 CALLE OYARZUN, 1 bajo
 20013 SAN SEBASTIAN
 Tel. 943 29 11 02 · fax 943 27 35 77
 www.garmasl.com · garma@garmasl.com