



## Kit auto-stable - Self aligning kit



- Construction en acier zingué
  - Etudié pour les applications pont-bascules
  - Dispositif anti-rotation intégré
  - Joints hermétiques sur chaque plaque
  - 2 hauteurs possibles (170 et 200 mm)
- 
- Made of zinc plated steel
  - Designed for weighbridge applications
  - Integrated anti-spinning device
  - Hermetic O-ring on each plate
  - 2 possible heights (170 and 200 mm)

Capteur vendu séparément  
Load cell sold separately

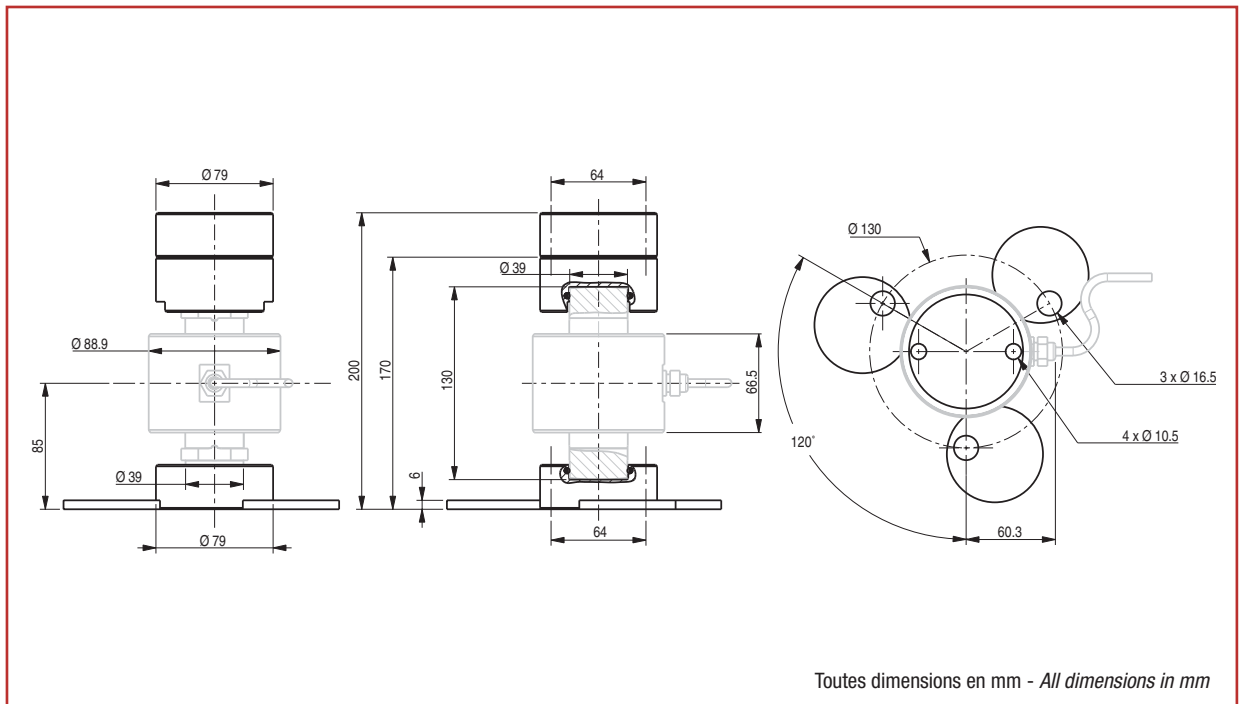

Note : avant utilisation, veuillez consulter notre Note Technique concernant les instructions et conseils de montage (NT-WEIGHBRIDGE-FE)  
Note : before use, please consult our Technical Note concerning mounting instructions (NT-WEIGHBRIDGE-FE)



BP501 - F-74105 Annemasse Cedex  
Tél. : (+33) 4 50 87 78 64  
Fax : (+33) 4 50 87 78 42  
E.mail : info@scaime.com



Agent



Garma Electrónica, S.L.  
CIF. B-20178372  
CALLE OYARZUN, 1 bajo  
20013 SAN SEBASTIAN  
Tel. 943 29 11 02 · fax 943 27 35 77  
www.garmasl.com · garma@garmasl.com