

Serie MPZ

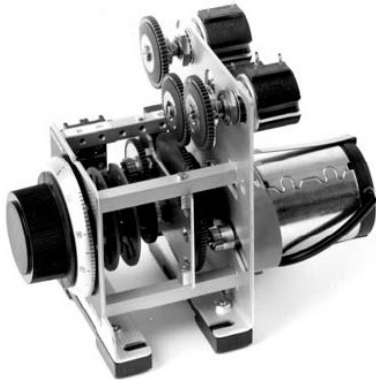

- **Zum Anbau von Potentiometer**
To mount external potentiometer
- **Anzahl Potentiometer** 1...3 (2W)
Number of potentiometer
- **Widerstandswerte** 100R...50K (Ω)
Resistance
- **Endlagenkontakte einstellbar** 2
Adjustable limit switches
- **Nutzkontakte** (frei programierbar) 1...4
Program channels (free setting)
- **Schnellbefestigung** 35 DIN 46277 / EN 50022
Quick rail mounting

Application:

- Motorized potentiometers are basically the best in the field of control and regulation technics
- The possibility to mount several potentiometers on the same shaft allows also a remote display of the position of the potentiometer
- Supplementary cams can be used to give limit signals depending on the position of the potentiometer
- Supplementary cams can also be used to offset a residual resistance of the potentiometer at the zero point
- One supplementary cam can be used as zero point interlocking

Design:

- High precision wire-wound potentiometer with high resolution and linearity
- Potentiometer directly driven by the cam shaft
- Two adjustable limit switches controlling the rotation angle of the potentiometer
- Solid mechanical Stopps preventing damage to potentiometers
- Available with AC or DC motors
- Friction clutch protecting the unit when manually operated
- The modular design allows quick delivery practically without delay, voltage resistance and cycle time according to your requirements

Outline drawing

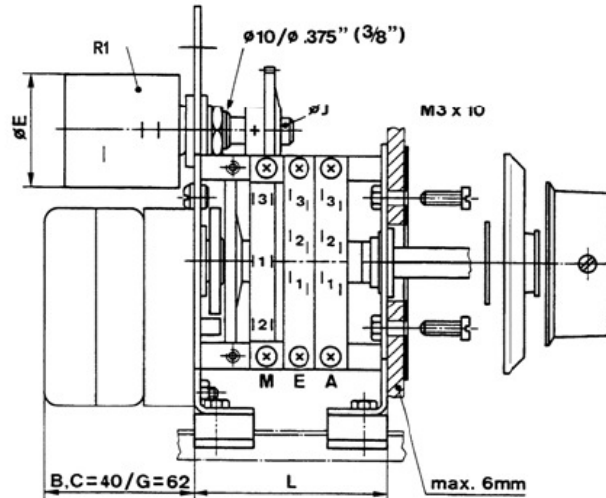
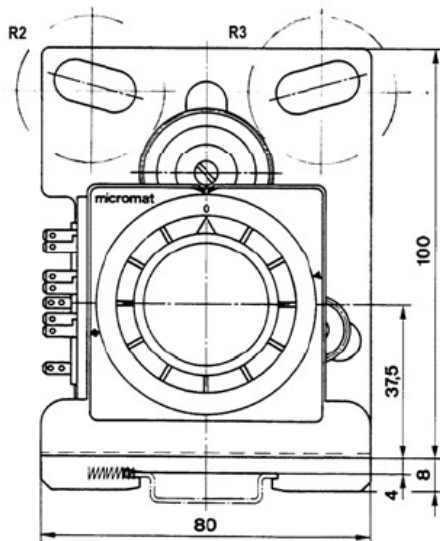

10 Turn-Motorized potentiometer drive

10 Gang-Motorpotentiometerantrieb

Serie MPZ

Order key

MPZ41 04 1 C1 1 1 0

incl. 1 Potentiometer, each further costs additionally in accordance with price list accessories
max. 3 Potentiometer

Size / Dimension (mm) / Number of switches:

4	-->Size
55 mm	-->Dimension (L)
04	= 2 Switches
2 Adjustable limit switches (NK4101/20%) + 0 Program channels free setting (NK4201)	
6	-->Size
71 mm	-->Dimension (L)
06	= 4 Switches
2 Adjustable limit switches (NK4101/20%) + 2 Program channels free setting (NK4201)	
1 Program key (PSN)	
9	-->Size
95 mm	-->Dimension (L)
09	= 6 Switches
2 Adjustable limit switches (NK4101/20%) + 4 Program channels free setting (NK4201)	
1 Program key (PSN)	

Cycle times (sec.):

1	= 20s	2	= 30s	3	= 45s
4	= 60s	5	= 90s	6	= 120s
				7	= 180s

Synchronous motor: Power supply (AC / DC) Frequency 50Hz (60Hz)

		CW	CCW	
C1	= 24	/	24V	AC
C2	= 48	/	48...	50V AC
C3	= 110	/	110...	120V AC
C4	= 220	/	220...	240V AC
G1	= 24	/	24V ± 0.1	DC
G2	= 12	/	12V ± 0.1	DC

On request

10-Turn-Precision wire wound potentiometer (Type DPZ, 2W): Resistance

1	= 100Ω	2	= 200Ω	3	= 500Ω	4	= 1KΩ
5	= 2KΩ	6	= 5KΩ	7	= 10KΩ		

10-Turn-Precision wire wound potentiometer (Type DPZ, 2W): Resistance

8	= 2.5KΩ	9	= 20KΩ	10	= 50KΩ
---	---------	---	--------	----	--------

Wire-wound potentiometer: Resistance

0	= -
1	= PRSG.2
2	= PSG.2
3	= PRSG.3
4	= PSG.3

Ex.: MPZ4104-7-G2-1094

meant for the potentiometer choice:
R1=50KΩ, R2=20KΩ, R3=1KΩ

Special products will be produced under a new article number.

10 Turn-Motorized potentiometer 10 Gang-Motorpotentiometer

Serie MPRZ

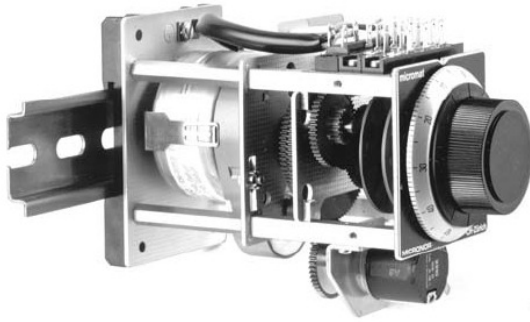

- | | |
|---|--------------------------------|
| • Feindrahtpotentiometer
Wire-wound potentiometer | R1...R3 (2W) |
| • Widerstandswerte
Resistance | 100R...50K (Ω) |
| • Endlagenkontakte einstellbar
Adjustable limit switches | 2 |
| • Nutzkontakte (frei programierbar)
Program channels (free setting) | 1...4 |
| • Rückwand- Schnellbefestigung
Quick rail base mounting | 35 DIN 46277 / EN 50022 |

Application:

- Motorized potentiometers are basically the best in the field of control and regulation technics
- The possibility to mount several potentiometers on the same shaft allows also a remote display of the position of the potentiometer
- Supplementary cams can be used to give limit signals depending on the position of the potentiometer
- Supplementary cams can also be used to offset a residual resistance of the potentiometer at the zero point
- One supplementary cam can be used as zero point interlocking

Design:

- High precision wire-wound potentiometer with high resolution and linearity
- Potentiometer directly driven by the cam shaft
- Two adjustable limit switches controlling the rotation angle of the potentiometer
- Solid mechanical Stopps preventing damage to potentiometers
- Available with AC or DC motors
- Friction clutch protecting the unit when manually operated
- The modular design allows quick delivery practically without delay, voltage resistance and cycle time according to your requirements

Outline drawing

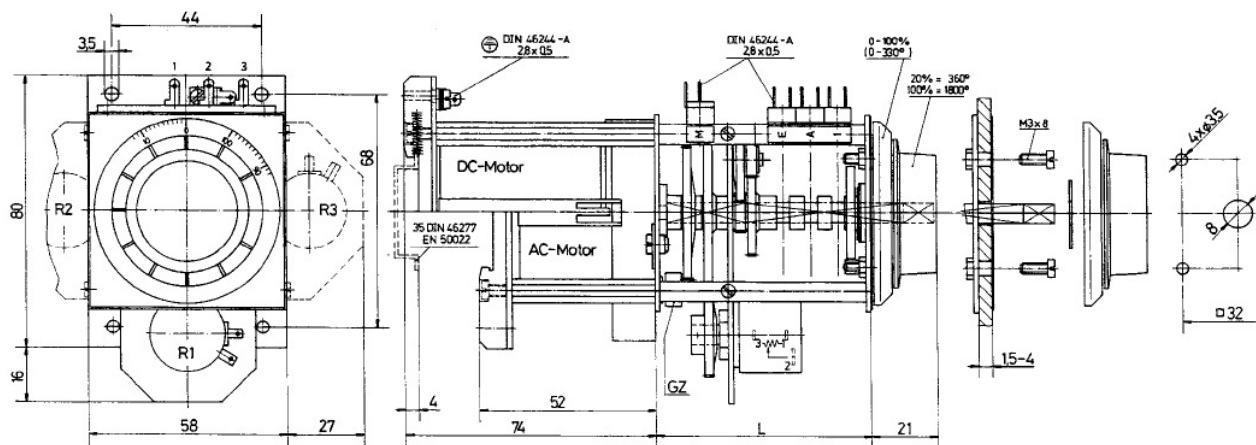

10 Turn-Motorized potentiometer 10 Gang-Motorpotentiometer

Serie MPRZ

Order key

MPRZ41 04 1 C1 1 1 0

incl. 1 Potentiometer, each further costs additionally in accordance with price list accessories
max. 3 Potentiometer

Size / Dimension (mm) / Number of switches:

- 4 -->Size
55 mm -->Dimension (L)
04 = 2 Switches
2 Adjustable limit switches (NK4101/20°) + 0 Program channels free setting (NK4201)
-
- 5 -->Size
63 mm -->Dimension (L)
05 = 3 Switches
2 Adjustable limit switches (NK4101/20°) + 1 Program channels free setting (NK4201)
1 Program key (PSN)
-
- 6 -->Size
71 mm -->Dimension (L)
06 = 4 Switches
2 Adjustable limit switches (NK4101/20°) + 2 Program channels free setting (NK4201)
1 Program key (PSN)

Cycle times (sec.):

- 1 = 30s 2 = 45s 3 = 60s
4 = 90s 5 = 120s 6 = 180s

Synchronous motor: Power supply (AC / DC) Frequency 50Hz (60Hz)

	CW	CCW	
C1 = 24	/ 24V		AC
C2 = 48	/ 48...	50V	AC
C3 = 110	/ 110...	120V	AC
C4 = 220	/ 220...	240V	AC
G1 = 24	/ 24V	± 0.1	DC
G2 = 12	/ 12V	± 0.1	DC

On request

Wire-wound potentiometer: Resistance

- 1 = 100Ω 2 = 200Ω 3 = 500Ω 4 = 1KΩ 5 = 2KΩ
6 = 5KΩ 7 = 10KΩ

Wire-wound potentiometer: Resistance

- 8 = 2.5KΩ 9 = 20KΩ 10 = 100KΩ

Wire-wound potentiometer: Resistance

- 0 = -
1 = PRSG.2
2 = PSG.2
3 = PRSG.3
4 = PSG.3

Ex.: MPRZ4106-5-G1-721-0

meant for the potentiometer choice:
R1=10KΩ, R2=200Ω, R3=100Ω

Special products will be produced under a new article number.

10 Turn-Motorized potentiometer drive 10 Gang-Motorpotentiometerantrieb

Serie MPZD

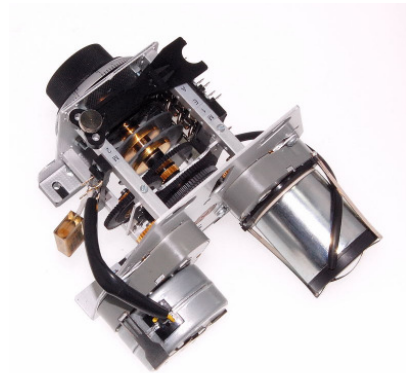

- 1-3 Feindrahtpotentiometer 2W/100 Ohm – 20 KOhm / Precision 10 turns potentiometer
- 2 Hochlaufzeiten / 2 Cycle time:
 - T1 = schneller Rücklauf / fast zero set
 - T2 = Programmablauf Max./Min. / Program duration Max./Min.
- 2 programmierbare Endlagekontakte / 2 Adjustable limit switches
- 1-7 programmierbare Nutzkontakte / 1-7 Adjustable program channel

Application:

- Motorized potentiometers are basically the best in the field of control and regulation technics
- The possibility to mount several potentiometers on the same shaft allows also a remote display of the position of the potentiometer
- Supplementary cams can be used to give limit signals depending on the position of the potentiometer
- Supplementary cams can also be used to offset a residual resistance of the potentiometer at the zero point
- One supplementary cam can be used as zero point interlocking

Design:

- High precision wire-wound potentiometer with high resolution and linearity
- Potentiometer directly driven by the cam shaft
- Two adjustable limit switches controlling the rotation angle of the potentiometer
- Solid mechanical Stopps preventing damage to potentiometers
- Available with AC or DC motors
- Friction clutch protecting the unit when manually operated
- The modular design allows quick delivery practically without delay, voltage resistance and cycle time according to your requirements

Outline drawing

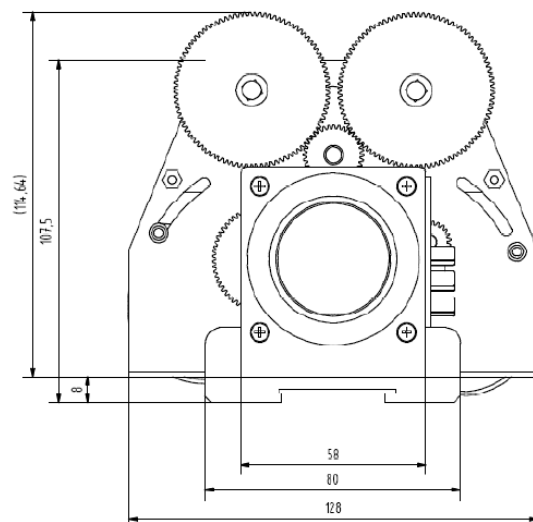
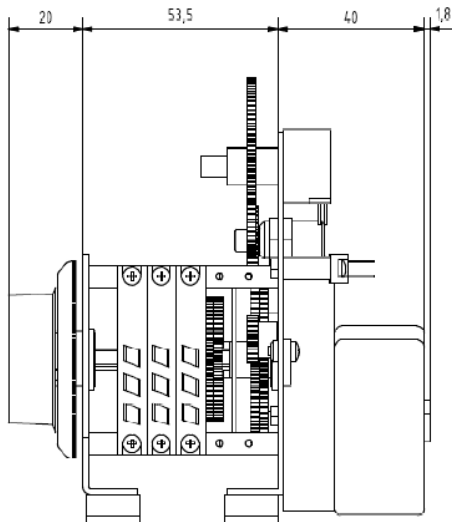

10 Turn-Motorized potentiometer drive

10 Gang-Motorpotentiometerantrieb

Serie MPZD

Order key

MPZD41 04 1 1 C1 C1 1 1

Dimension / Size (mm) / Number of switches:

4	-->Dimension
55 mm	-->Size (L)
04	= 2 Switches
2 Adjustable limit switches (NK4101/20°) + 0 Program channels free setting (NK4201)	
5	-->Dimension
63 mm	-->Size (L)
05	= 3 Switches
2 Adjustable limit switches (NK4101/20°) + 1 Program channels free setting (NK4201)	
1 Program key (PSN)	
6	-->Dimension
71 mm	-->Size (L)
06	= 4 Switches
2 Adjustable limit switches (NK4101/20°) + 2 Program channels free setting (NK4201)	
1 Program key (PSN)	
9	-->Dimension
95 mm	-->Size (L)
09	= 7 Switches
2 Adjustable limit switches (NK4101/20°) + 5 Program channels free setting (NK4201)	
1 Program key (PSN)	

Cycle times (T1):

1 = 30s 2 = 60s 3 = 100s 4 = 150s 5 = 180s 6 = 300s
 7 = 10min. 8 = 15min. 9 = 20min. 10 = 30min. 11 = 60min.

Cycle times (T2):

1 = 30s 2 = 60s 3 = 100s 4 = 150s 5 = 180s 6 = 300s
 7 = 10min. 8 = 15min. 9 = 20min. 10 = 30min. 11 = 60min.

Synchronous motor 1: Power supply (AC / DC) Frequency 50Hz (60Hz)

		CW	CCW	
C1	= 24	/	24V	AC
C2	= 48	/	48... 50V	AC
C3	= 110	/	110... 120V	AC
C4	= 220	/	220... 240V	AC
G1	= 24	/	24V ± 0.1	DC
G2	= 12	/	12V ± 0.1	DC
				On request

Synchronous motor 2: Power supply (AC / DC) Frequency 50Hz (60Hz)

		CW	CCW	
C1	= 24	/	24V	AC
C2	= 48	/	48... 50V	AC
C3	= 110	/	110... 120V	AC
C4	= 220	/	220... 240V	AC
G1	= 24	/	24V ± 0.1	DC
G2	= 12	/	12V ± 0.1	DC
				On request

10-Turn-Precision wire wound potentiometer (Type DPZ, 2W): Resistance

1 = 100Ω 2 = 200Ω 3 = 500Ω 4 = 1KΩ
 5 = 2KΩ 6 = 5KΩ 7 = 10KΩ

10-Turn-Precision wire wound potentiometer (Type DPZ, 2W): Resistance

8 = 20KΩ 9 = 50KΩ

Ex.: MPZD4105-1-C4-C4-718 meant for the potentiometer choice:
 R1=10KΩ, R2=100Ω, R3=2.5KΩ

Special products will be produced under a new article number.