

## Thermal Dispersion & Paddle Type Level Switch

**GARMA**  
ELECTRÓNICA S.L.



Garma Electrónica, S.L.  
CIF. B-20178372  
CALLE OYARZUN, 1 bajo  
20013 SAN SEBASTIAN  
Tel. 943 29 11 02 · fax 943 27 35 77  
[www.garmasl.com](http://www.garmasl.com) · [garma@garmasl.com](mailto:garma@garmasl.com)





# PRODUCT SPECIFICATION

Drawing			
Model	<b>SP200-□-□-□-□-□</b> <b>Compact Type</b>	<b>SP201-□-□-□-□-□</b> <b>Extension Type</b>	<b>SP202-□-□-□-□-□</b> <b>High Temp. Type</b>
Measuring Range	Water: 1~150 cm/s Oil: 3~300 cm/s	Water: 1~150 cm/s Oil: 3~300 cm/s	Water: 1~150 cm/s Oil: 3~300 cm/s
Ambient Temperature	-20 ~ 80°C	-20 ~ 80°C	-20 ~ 80°C
Operating Temperature	-20 ~ 80°C	-20 ~ 80°C	-20 ~ 120°C
Alarm Output	Open Collector : NPN / PNP(<400mA) Relay : 1A/30Vdc, 0.3A/125Vac (NO or NC)		
Operating Pressure	100 bar (max.)	100 bar (max.)	100 bar (max.)
LED Indication:	Flow velocity below set point- Red LED on, Open Flow velocity equals set point- Yellow LED on, Close Flow velocity above set point- 4 Green LED to indicate flow speed, Close		
Housing	SUS304 / 316L	SUS304 / 316L	SUS304/ 316/ 316L
Protection Level	IP67		
Warm-up Time	Approx.10 Sec	Approx.15 Sec	Approx.15 Sec
Connection Thread	G1/2, G1/4, NPT1/2	G1/2, NPT1/2	G1/2, G1/4, NPT1/2
Operating Voltage	19 ~ 30Vdc		
Power consumption	50mA (max.)		
Wiring	3-wire NPN/PNP Power-brown Grounding-blue Output-black		
Accessory	Gasket, 2m Cable		

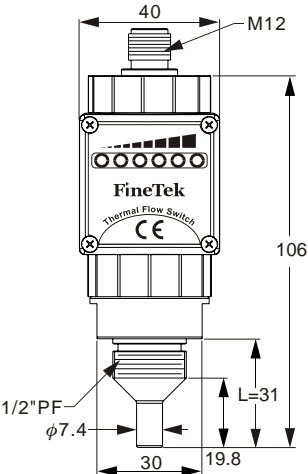
# PRODUCT SPECIFICATION

Drawing	
Model	<b>SP220-□-□□-□□ Economy Type</b>
Measuring Range	Water: 1~150 cm/s Oil: 3~300 cm/s
Ambient Temperature	-20 ~ 80°C
Operating Temperature	-20 ~ 80°C
Alarm Output	Open Collector : NPN / PNP (<400mA) Relay : 1A/30Vdc, 0.3A/125Vac (NO or NC)
Operating Pressure	100 bar (max.)
LED Indication:	Flow velocity below set point- Red LED on, Open Flow velocity equals set point- Yellow LED on, Close Flow velocity above set point- 4 Green LED to indicate flow speed, Close
Housing	PC
Protection Level	IP65
Warm-up Time	Approx. 15 Sec
Connection Thread	G1/2, NPT1/2
Operating Voltage	19 ~ 30Vdc
Power consumption	50mA (max.)
Wiring	3-wire NPN/PNP Power-brown Grounding-blue Output-black
Accessory	Gasket, 2m Cable
Footnote	Can not set Sensitivity and Alarm

# PRODUCT SPECIFICATION

Drawing		
	 Cert. Number GYJ071446	
Model	<b>SP210 Stainless Steel Type</b>	<b>SP170-(1/2) Explosion Proof Type</b>
Measuring Range	Water: 1~150 cm/s Oil: 3~300 cm/s	Water: 1~150 cm/s Oil: 3~300 cm/s
Ambient Temperature	-20 ~ 80°C	-20 ~ 80°C
Operating Temperature	-20 ~ 80°C	-20 ~ 80°C
Alarm Output	Relay: 5A/250Vac	Relay: 5A/250Vac
Operating Pressure	100 bar (max.)	100 bar (max.)
LED Indication:	Flow velocity below set point- Red LED on, Open Flow velocity equals set point- Yellow LED on, Close Flow velocity above set point- 4 Green LED to indicate flow speed, Close	
Housing	SUS304	SUS304
Wetted material	SUS304 / 316 / 316L	SUS304 / 316 / 316L
Protection Level	IP67	IP67
Warm-up Time	Approx.15 Sec	Approx.15 Sec
Connection Thread	G1/2, NPT1/2	G1/2, NPT1/2
Operating Voltage	19 ~ 30Vdc	19 ~ 30Vdc
Power consumption	60mA (max.)	60mA (max.)
Wiring	5-wire Relay Output Power- red Grounding- black COM- white NC- yellow NO- blue	
Accessory	Gasket, 2m Cable	_____

# INSTALLATION

## INSTALLATION

Please use given water-proof gasket for installing.

1. "a" above and below the SP in diagram 1 has to be 4 times greater than its internal diameter of pipe.(Fig. 1)
2. Make sure that the pipe is bubble-free for proper alarming.(Fig. 2)
3. For not-fully-filled pipes, SP needs to be installed underneath. Liquid level needs to be higher than the probe height. (Fig. 3)
4. SP must be screwed tightly to avoid liquid leakage from leaking out. It can be installed in any angle. For best sensitivity and response speed, please refer to the installation in (Fig. 4)
5. This is to protect the wear and tear to the device. Please install filter upstream the Spin case impurities in the liquid destroy the SP.

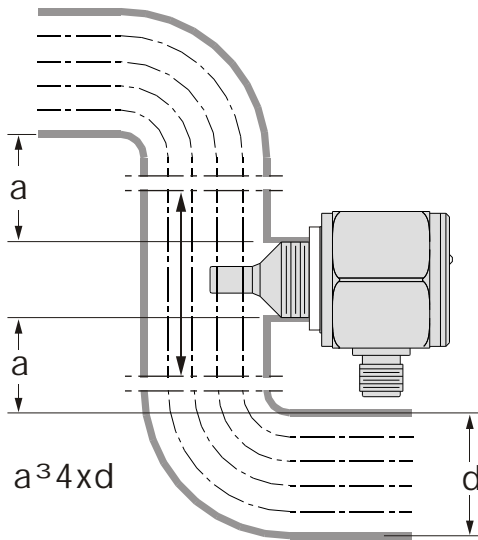

Fig. 1

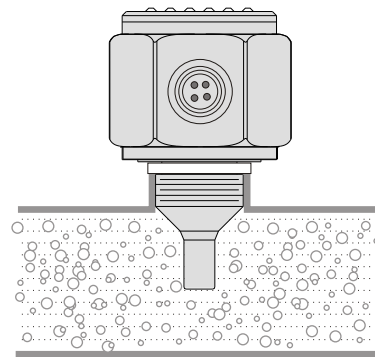

Fig. 2

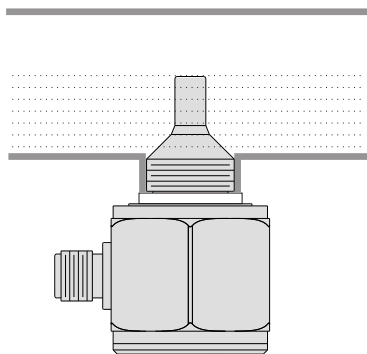

Fig. 3

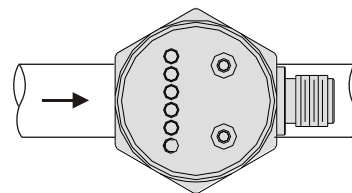

Fig. 4

## CONNECTOR DIAGRAM

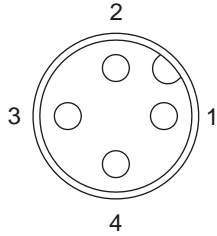

Fig. 5  
Wire terminal diagram  
(NPN, PNP and 1A relay output type)

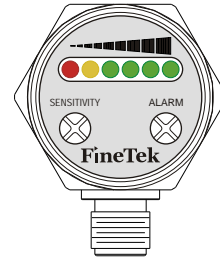

Fig. 6

## WIRING

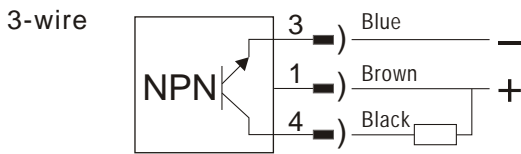

Fig. 7, NPN output type wiring

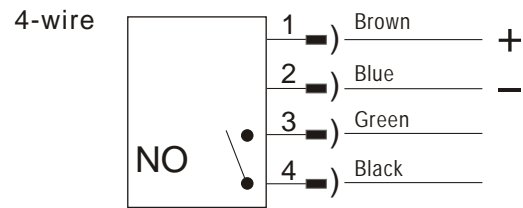

Fig. 10, Relay output type wiring (NO)

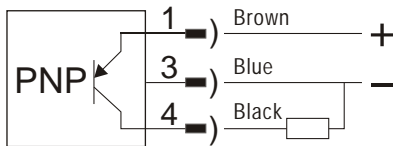

Fig. 8, PNP output type wiring

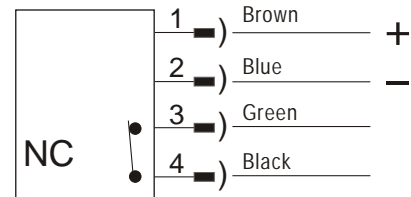

Fig. 11, Relay output type wiring (NC)

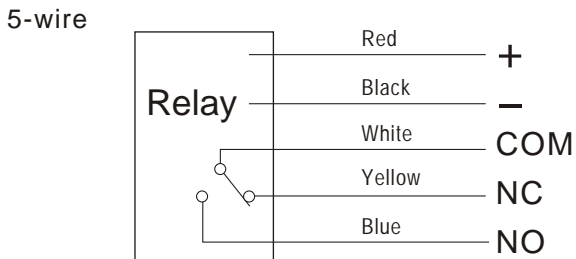

Fig. 9, Relay output type wiring

# CODE NAME INFORMATION

SP2   -  -   -  -  - (     )

**Model Description**

- 0: Compact Type
- 1: Stainless Steel Type  $\phi 70 \times 78$   
(for SPDT 5A/250Vac)
- 2: Economy Type (Plastic Housing)

**Probe Type**

- 0: Standard Type
- 1: Probe Extension Type
- 2: 120°C High Temperature Type  
(Except SP220)

**Material**

- 0: SUS304    L: SUS316L    S: Other
- 6: SUS316    F: PVDF (for SP203 only)

**Connection**

Size	Specification
A: 3/8" (10A)	Q: PT
B: 1/2" (15A)	T: BSP
C: 3/4" (20A)	R: PF
D: 1" (25A)	U: NPT
2: 1/4"	V: GAS
S: Other	S: Other

\*Standard thread connection: 1/2"PF, 1/2"NPT, 1/2"PT

**Output**

- N: NPN (current limit: 400mA)
- P: PNP (current limit: 400mA)
- A: Relay 1A/30Vdc (NO)
- B: Relay 1A/30Vdc (NC)
- C: Relay 5A/250Vac (NC) (for SP210/ SP211/ SP212)

**Cable Wire Length(unit: m)**

- 0: None    2: 2m    5: 5m

**Length L (Unit: mm)**

- \* Tolerance of the total product length is  $\pm 5\text{mm}$
- \* In case of not affecting original functions, dimensions are subject to change without notice.
- \* Please contact us for specific extension probe.
- \* Max.200mm
- \* PVDF and PTFE are available for standard models.

# CODE NAME INFORMATION

SP170-  -  -  - ()

**Model Description**

70 ---Explosion Proof Type

**Material**

1: SUS304  
2: SUS316L

Size	Specification
B: 1/2" (15A) D: 1" (25A) S: Other	Q: PT T: BSP R: PF V: GAS U: NPT S: Other

**Output**

C: SPDT 5A/250Vac

**Length L (Unit: mm)**

- \* Please contact us for specific extension probe.
- \* In case of not affecting original functions, dimensions are subject to change without notice.
- \* Tolerance of the total product length is  $\pm 5\text{mm}$
- \* Max.200mm

# PADDLE TYPE FLOW SWITCH

## Principle

Flow Switch utilizes the force of liquid flow to propel its paddle in order to detect the incoming flow or moving of the existing liquid in pipe. In condition of static liquid or no liquid, the spring is in expanding and press the magnet downward vertically. Reed switch contact is N.O.

As flow occurs and the paddle is thrust to raise at an upward angle of 20°~30° (or more). The eccentric of paddle will push the magnet upward to actuate the reed switch which is thus in a close circuit. The length of paddle can be adjusted with the diameter of a pipe.

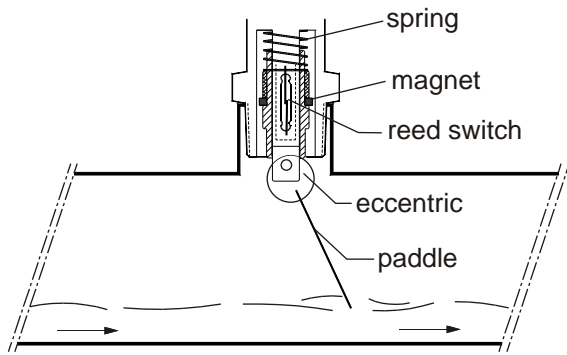

Switch on in case of liquid flowing in pipes

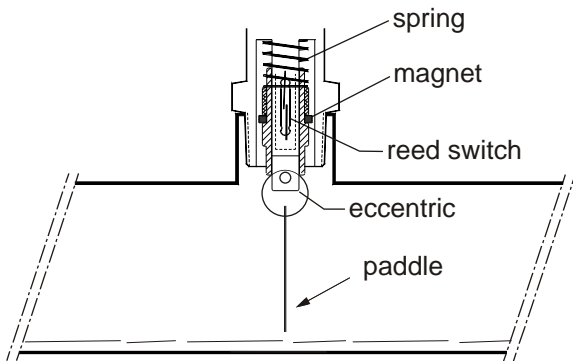

Switch off in case of no moving liquid in pipes

## SECTIONAL DRAWINGS

1. O-Ring
2. Paddle
3. Eccentric
4. Reed switch
5. Spring
6. Magnet
7. Housing
8. Screw
9. Center rod

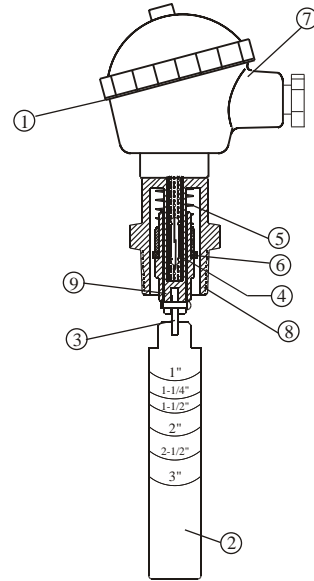

NEPSI  $\text{Ex}$

**MODEL: Sf1710**  
Explosion proof type

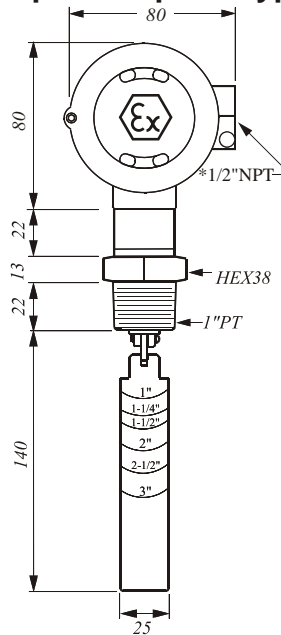

**MODEL: Sf1800**  
Standard type

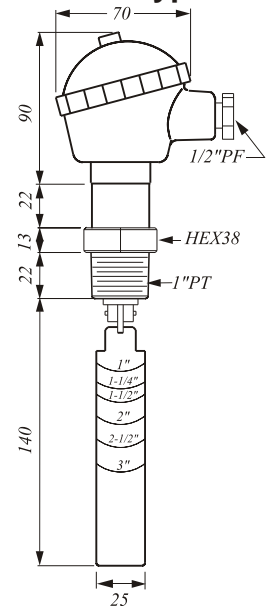

\*Optional part 1/2\"NPT

Spec.	Model	SF1710	SF1800
Housing Material		Aluminum Alloy, Ex d IIC T6	Aluminum Alloy, IP65
Operation Temp.		-30°C~100°C	-30°C~150°C
Wetted Material		SUS304	SUS304
Operation Pressure		Max. 355 PSIG	Max. 355 PSIG
Pressure Drop Allowance		3 PSIG	3 PSIG
Set Point Tolerance		± 25%	± 25%
Repeatability Tolerance		± 5%	± 5%
Contact Capacity		60W 220Vac/200Vdc, SPDT	60W 220Vac/200Vdc, SPDT

## FLOW CONTROL RANGE TABLE

Paddle Length Flow Volume Gallon / Min.	1"		1-1/4"		1-1/2"		2"		2-1/2"		3"	
	Act.	De-Act.	Act.	De-Act.	Act.	De-Act.	Act.	De-Act.	Act.	De-Act.	Act.	De-Act.
1"	5	4	8.5	6.5	12	9	17	15				
1-1/4"			6.5	4.5	9	7	15	12	23	20		
1-1/2"					14	10	23	16	32	25		
2"							18	12	24	17	33	27
2-1/2"									20	13	27	22
3"											22	16

※ 1 Gallon=3.872 Litter

## INSTALLATION

- Paddle length conditions actuation setting of a Flow Switch unit. Paddle length is decided according to the lowest point of paddle while actuating the reed switch and the diameter of the pipe. Cut off the paddle at proper pipe size mark or wherever desired but not less than 1" left.
  - The paddle must be parallel to the cutting face of a pipe and the mounting screw is 1" NPT.
  - The FLOW mark on the screw hexagon must be parallel to the pipe and the ground.
  - Before installing the unit to a tee pipe, be sure to apply tape seal to the screw then tighten up.
- It is not recommended to the 1" NPT plastic pipe.

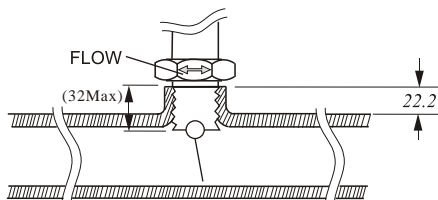

## CAUTION

- The pressure and temperature ranges as shown in the catalog, must not be exceeded and also take the abrupt pressure and temperature into considerations.
- Operating temperature changes do affect switch set points. In case of the liquid temperature would vary with the specific gravity changes during processing, please contact us for assistance.
- The flow switch is designed for shock and vibration resistance. However, shock and vibration should be as minimized as possible.
- Excessive contamination in fluid might inhibit Paddle operation, occasional wipe-down would be necessary.
- Electrical entry and mounting require sealing from moisture.
- Please don't modify the outlook of product.