

## MODEL ITMS - INTELLIGENT TEMPERATURE TO MODBUS CONDITIONER W/ ALARMS

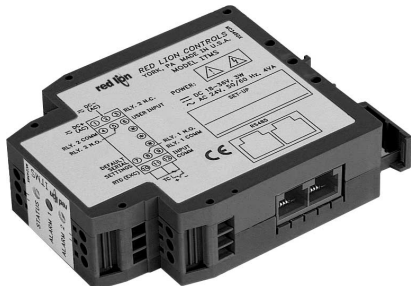

- TEMPERATURE TO MODBUS CONVERSION
- ACCEPTS THERMOCOUPLE, RTD, mV OR RESISTANCE SIGNALS
- PROCESSOR BASED SCALING
- PC CONFIGURATION SOFTWARE
- DUAL SETPOINT RELAY ALARMS
- FOUR WAY SIGNAL ISOLATION



UL Recognized Component,  
 File # E179259

### GENERAL DESCRIPTION

The ITMS4037 Intelligent Temperature to MODBUS™ Conditioner with Alarms accepts a wide range of temperature sensors (thermocouple and RTD elements), and converts the signal into a register format that can be read using either ASCII or RTU MODBUS protocol.

The ITMS allows a choice of either Fahrenheit or Celsius readout with 0.1 or 1 degree of resolution. An offset value can be programmed to scale the input signal to meet most process requirements. Additionally, two setpoint values can be entered for dual relay process monitoring alarms.

The ITMS is programmed with Windows™ based SFIMS software. The software allows configuration, calibration, and storage of ITMS program files. Additionally, all setup parameters can be interrogated and modified through MODBUS register and coil commands.

The RS485 port allows the ITMS to be multidropped, with Baud rates up to 38400. The CBPRO007 programming cable converts the RS232 port of a PC to RS485, and is terminated with an RJ-11 connector. The bidirectional capability of the CBPRO007 allows it to be used as a permanent interface cable as well as a programming cable.

The ITMS's two relay alarms can be configured independently for absolute high or low acting with balanced or unbalanced hysteresis. Alarm 2 can also be configured for deviation and band alarms. In these modes, Setpoint 2 tracks Setpoint 1. Adjustable alarm trip delays can be used for delaying output response. The alarms can be programmed for Automatic or Latching. Latched alarms can be reset with a serial command or a user input. A standby feature suppresses the alarm during power-up until the temperature stabilizes outside the alarm region. Standby eliminates power-up tripping for low acting alarms. A user input can be used to set and reset non-latching alarms. The output relays can also be manually controlled with register commands.

The module's high density packaging and DIN rail mounting saves time and panel space. The module is equipped with a universal mounting foot for attachment to standard DIN rails, including top hat (T) profile or G profile rail.

### ORDERING INFORMATION

MODEL	DESCRIPTION	PART NUMBER
ITMS	Temperature to MODBUS Conditioner w/Alarms	ITMS4037
SFIMS	PC Configuration Software for Windows	SFIMS
CBPRO	Programming Interface Cable	CBPRO007
CBJ	Cable RJ11 to Unterminated 7 foot length	CBJ11A07
	Cable RJ11 to RJ11 6 inch jumper	CBJ11BD5
	RJ Connector to Terminal Adapter	DRRJ11T6

### SAFETY SUMMARY

All safety related regulations, local codes and instructions that appear in the manual or on equipment must be observed to ensure personal safety and to prevent damage to either the instrument or equipment connected to it. If equipment is used in a manner not specified by the manufacturer, the protection provided by the equipment may be impaired.

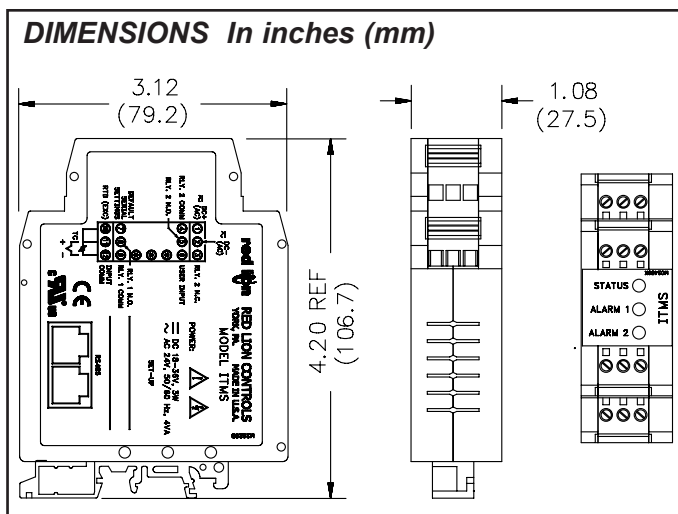
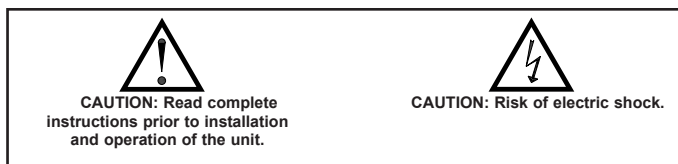

## SPECIFICATIONS

- POWER:** 18-36 VDC, 3.0 W max. or 24 VAC,  $\pm 10\%$ , 50/60 Hz, 4 VA max.
- INPUT:**
  - Sample Rate: 67 msec. (15 Hz)
  - Failed Sensor Response: Open or shorted (RTD only) sensor coils indication, error code returned in Process Value
  - Common Mode Rejection: 50/60 Hz, 110 dB min.
  - Overvoltage: 30 VDC
  - Response Time: 150 msec. max.
- THERMOCOUPLE INPUTS:**
  - Types: T, E, J, K, R, S, B, N, C, linear mV
  - Input Impedance: 20 M $\Omega$
  - Lead Resistance Effect: 0.22  $\mu\text{V}/\Omega$
  - Resolution: 1° or 0.1° for all types

TC TYPE	DISPLAY RANGE	WIRE COLOR	
		ANSI	BS 1843
T	-200 to +400°C -328 to +752°F	(+) blue (-) red	(+) white (-) blue
E	-200 to +750°C -328 to +1382°F	(+) violet (-) red	(+) brown (-) blue
J	-200 to +760°C -328 to +1400°F	(+) white (-) red	(+) yellow (-) blue
K	-200 to +1372°C -328 to +2502°F	(+) yellow (-) red	(+) brown (-) blue
R	0 to +1768°C +32 to +3214°F	No Standard	(+) white (-) blue
S	0 to +1768°C +32 to +3214°F	No Standard	(+) white (-) blue
B	+200 to +1820°C +392 to +3308°F	No Standard	No Standard
N	-200 to +1300°C -328 to +2372°F	(+) orange (-) red	(+) orange (-) blue
C W5/W26	0 to +2315°C +32 to +4199°F	No Standard	No Standard
mV	-10 mV to 65 mV	NA	NA

- RTD INPUTS:**
  - Type: 2 or 3 wire
  - Excitation: 150  $\mu\text{A}$
  - Lead Resistance: 10  $\Omega$  max.
  - Resolution: 1° or 0.1° for all types

RTD TYPE	INPUT TYPE	RANGE
385	100 $\Omega$ platinum, Alpha=.00385	-200 to +800°C -328 to +1472°F
392	100 $\Omega$ platinum, Alpha=.003919	-200 to +800°C -328 to +1472°F
672	120 $\Omega$ nickel, Alpha=.00672	-80 to +260°C -112 to +500°F
Ohms	Linear Resistance	0 to 440 $\Omega$

- INDICATION ACCURACY:**  $\pm(0.3\%$  of span, +1°C), includes NIST conformity, cold junction effect, A/D conversion errors, tempco and linearization conformity at 23°C after 20 minute warm-up.  
Span Drift (max) : 0.01% /°C
- USER INPUT:** Internally pulled up to +5 VDC.  $V_{IL} = 0.78$  V max.,  $V_{IH} = 1.8$  V min.  $I_{OFF} = 9$   $\mu\text{A}$  max. 30 V max. over voltage continuously.
- ISOLATION LEVEL:** 1.5 KV @ 50/60 Hz, 1 minute (150 V working) between input, RS485 and power supply. 2300 Vrms, 1 minute (300 V working) to relay contacts.
- SERIAL COMMUNICATIONS:**
  - Type: RS485; RTU and ASCII MODBUS modes
  - Baud: 300, 600, 1200, 2400, 4800, 9600, 19200, and 38400
  - Format: 7/8 bit, odd, even and no parity
  - Transmit Delay: Programmable. (See Transmit Delay explanation in Step 6)
  - Transmit Enable (TXEN): (primarily for 20 mA loop converter) open collector  $V_{OH} = 10$  VDC max.  $V_{OL} = 0.5$  VDC @ 5 mA max. current limit
- A/D CONVERTER:** 16 bit resolution
- RELAY OUTPUTS:**
  - Type: 1 Form A N.O. contacts, 1 Form C DPDT
  - Rating: 5A @ 30 VDC or 250 VAC max. (resistive)
  - 1/10 HP @ 120 VAC (inductive)
  - Response Time: 155 msec. max. to close including step response, 153 msec. max. to open.
  - Output On Delay Time: Programmable from 0 to 32000 sec  $\pm 0.01\%$  - 1 sec. max.

- MEMORY:** Nonvolatile E<sup>2</sup>PROM retains all programmable parameters.
- ENVIRONMENTAL CONDITIONS:**
  - Operating Temperature Range: -20 to +65 °C
  - Storage Temperature Range: -40 to +85 °C
  - Operating and Storage Humidity: 85% max. relative humidity (non-condensing) from -20 to +65 °C
  - Altitude: Up to 2000 meters
- CERTIFICATIONS AND COMPLIANCE:**

### SAFETY

UL Recognized Component, File # E179259, UL3101-1, CSA 22.2 No. 1010-1  
 Recognized to U.S. and Canadian requirements under the Component Recognition Program of Underwriters Laboratories, Inc.  
 IECEE CB Scheme Test Certificate # US/5141A/UL,  
 CB Scheme Test Report # 01ME11540-0702001  
 Issued by Underwriters Laboratories, Inc.  
 IEC 1010-1, EN 61010-1: Safety requirements for electrical equipment for measurement, control, and laboratory use, Part 1.

### ELECTROMAGNETIC COMPATIBILITY

#### Immunity to EN 50082-2

Electrostatic discharge	EN 61000-4-2	Level 2; 4 KV contact Level 3; 8 KV air <sup>1</sup>
Electromagnetic RF fields	EN 61000-4-3	Level 3; 10 V/M 80 MHz - 1 GHz
Fast transients (burst)	EN 61000-4-4	Level 4; 2 KV I/O Level 3; 2 KV power
RF conducted interference	EN 61000-4-6	Level 3; 10 V/rms 150 KHz - 80 MHz
Simulation of cordless telephone	ENV 50204	Level 3; 10 V/m 900 MHz $\pm 5$ MHz 200 Hz, 50% duty cycle

#### Emissions to EN 55011

RF interference	EN 55011	Enclosure class A Power mains class A
-----------------	----------	--

#### Notes:

- This device was designed for installation in an enclosure. To avoid electrostatic discharge to the unit in environments with static levels above 6 KV, precautions should be taken when the device is mounted outside an enclosure. When working in an enclosure (ex. making connections, etc.), typical anti-static precautions should be observed before touching the module. Refer to the EMC Installation Guidelines section of this bulletin for additional information.

- CONSTRUCTION:** Case body is black high impact plastic. Installation Category II, Pollution Degree 2.
- CONNECTIONS:** Wire clamping screw terminals.
- MOUNTING:** Universal mounting foot for attachment to standard DIN style mounting rails, including top hat (T) profile rail according to EN50022 - 35 x 7.5 and -35 x 15, and G profile rail according to EN50035 - G32.
- WEIGHT:** 4.5 oz. (127.57 g)

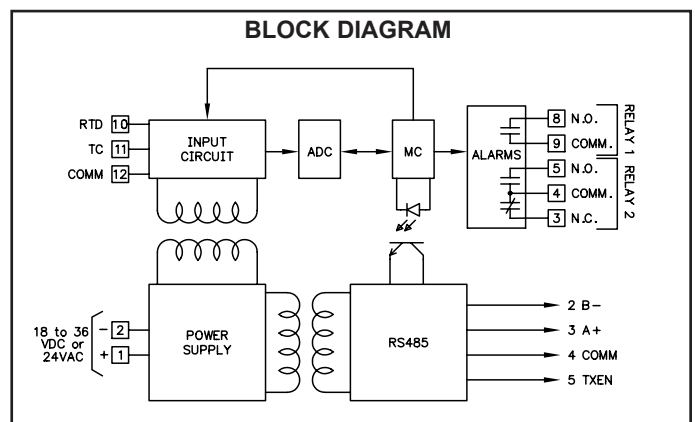

## MODULE ISOLATION

The ITMS features “4-way” signal isolation. The 4-way isolation is a combination of optical, transformer and relay barriers, providing common mode voltage (CMV) isolation to 1.5 KV for 1 minute between input, RS485, and power supply. Isolation between relay contacts and all other inputs is 2300 Vrms for 1 minute.

## LED FUNCTIONALITY

CONDITION	GREEN LED	2 RED LEDS
Power Applied	On	——
Communication Received	Flashing	——
Respective Alarm	On	On
Checksum error	Flashing	Flashing
Calibration	Off	On

---

## EMC INSTALLATION GUIDELINES

Although this module is designed with a high degree of immunity to Electro-Magnetic Interference (EMI), proper installation and wiring methods must be followed to ensure compatibility in each application. The type of the electrical noise, source or coupling method into the unit may be different for various installations. Cable length, routing, and shield termination are very important and can mean the difference between a successful or troublesome installation.

Listed below are some EMC guidelines for successful installation in an industrial environment.

1. Use shielded (screened) cables for all Signal and Control inputs. The shield (screen) pigtail connection should be made as short as possible. The connection point for the shield depends somewhat upon the application. Listed below are the recommended methods of connecting the shield, in order of their effectiveness.
  - a. Connect the shield only at the rail where the unit is mounted to earth ground (protective earth).
  - b. Connect the shield to earth ground at both ends of the cable, usually when the noise source frequency is above 1 MHz.
  - c. Connect the shield to common of the unit and leave the other end of the shield unconnected and insulated from earth ground.
2. Never run Signal or Control cables in the same conduit or raceway with AC power lines, conductors feeding motors, solenoids, SCR controls, and heaters, etc. The cables should be run in metal conduit that is properly grounded. This is especially useful in applications where cable runs are long and portable two-way radios are used in close proximity or if the installation is near a commercial radio transmitter.

3. Signal or Control cables within an enclosure should be routed as far away as possible from contactors, control relays, transformers, and other noisy components.

4. In extremely high EMI environments, the use of external EMI suppression devices, such as ferrite suppression cores, is effective. Install them on Signal and Control cables as close to the unit as possible. Loop the cable through the core several times or use multiple cores on each cable for additional protection. Install line filters on the power input cable to the unit to suppress power line interference. Install them near the power entry point of the enclosure. The following EMI suppression devices (or equivalent) are recommended:

Ferrite Suppression Cores for signal and control cables:

Fair-Rite # 0443167251 (RLC # FCOR0000)

TDK # ZCAT3035-1330A

Steward # 28B209-0A0

Line Filters for input power cables:

Schaffner # FN610-1/07 (RLC # LFIL0000)

Schaffner # FN670-1.8/07

Corcom # 1 VR3

*Note: Reference manufacturer's instructions when installing a line filter.*

5. Long cable runs are more susceptible to EMI pickup than short cable runs. Therefore, keep cable runs as short as possible.

# STEP 1 WIRING THE MODULE

## WIRING CONNECTIONS

All conductors should meet voltage and current ratings for each terminal. Also, cabling should conform to appropriate standards of good installation, local codes and regulations. When wiring the module, use the numbers on the label to identify the position number with the proper function. Strip the wire, leaving approximately 1/4" (6 mm) of bare wire exposed. Insert the wire into the terminal, and tighten the screw until the wire is clamped tightly. (Pull wire to verify tightness.) Each terminal can accept up to one #14 AWG (2.55 mm), two #18 AWG (1.02 mm), or four #20 AWG (0.61 mm) wires.

## MODULE POWER CONNECTIONS

AC module power is connected to terminals 1 and 2. DC module power is connected with (+) to terminal 1 and (-) to terminal 2. For best results, the power should be relatively "clean" and within the specified limits. Drawing power from heavily loaded circuits or from circuits that also power loads that cycle on and off should be avoided. It is recommended that power supplied to the module be protected by a fuse or circuit breaker.

## INPUT CONNECTIONS

### Thermocouple Input

Thermocouple leads are connected to terminals 11 (+) and 12 (-).

### RTD Input

For 3-wire RTD elements, connect the sense leads to terminals 11 and 12. The excitation lead is connected to terminal 10 (EXC).

For 2-wire RTD elements, connect the sense leads to terminals 11 and 12. Install a copper sense lead of the same gauge and length as the RTD leads. Attach one end of the wire at the probe and the other end to terminal 10. Complete lead wire compensation is obtained. This is the preferred method. If a sense wire is not used, then Terminal 11 should be shorted to terminal 10. A temperature offset error will exist. The error may be compensated by programming a temperature offset.

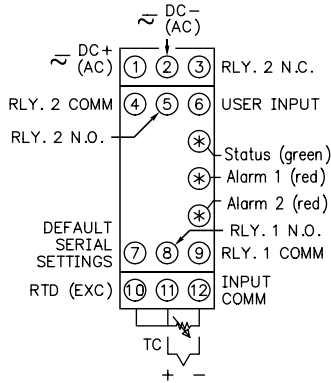

## RELAY OUTPUT CONNECTIONS

### Relay 1

Relay 1 is a Form A output relay. Wiring is connected between terminal 9 (COMM.) common and terminal 8 (N.O.) the normally open contact.

### Relay 2

Relay 2 is a Form C output relay. Wiring is connected between terminal 4 (COMM.) common and either terminal 5 (N.O.), the normally open contact, or terminal 3 (N.C.), the normally closed contact.

To prolong contact life and suppress electrical noise interference due to the switching of inductive loads, it is good installation practice to install a snubber across the contacts. Follow the manufacturer's instructions for installation.

*Note: Snubber leakage current can cause some high impedance loads to be held ON.*

## DEFAULT SERIAL SETTING CONNECTION

If the ITMS settings are unknown, or forgotten, they can be reset to the factory defaults by connecting the Serial Default terminal 7 to Input Comm. terminal 12 with a jumper, and then cycling power.

### Defaults:

Protocol: RTU      Data Bits: 8  
 Address: 247      Parity: none  
 Baud Rate: 9600

## USER INPUT CONNECTION

The user input is activated when terminal 6 is pulled low (connected to Input Comm. terminal 12).

## RS485 SERIAL CONNECTIONS

There are two RJ-11 connectors located on the bottom for paralleling communications. For single device communications, either connector can be used. When used in conjunction with Red Lion Control Paradigm HMI products, reverse A+ and B- wiring.

RJ11	ITMS
1	Not used
2	B-
3	A+
4	COMM
5	TXEN
6	Not used

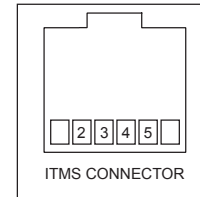

# STEP 2 INSTALLING SFIMS (Software for Intelligent Modules)

Insert the SFIMS diskette into the A: or B: drive. Then Run A:\SETUP (or B:\SETUP) to install RLCPro onto the hard drive. An icon labeled RLCPro will be created under the group RLCPro.

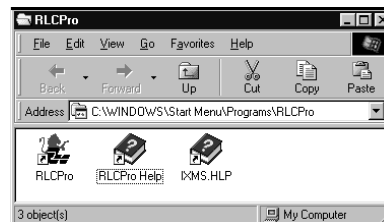

## STEP 3 PROGRAMMING - Getting Started

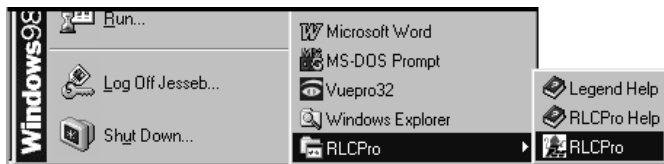

Run RLCPro by double-clicking the icon, or use the start menu.

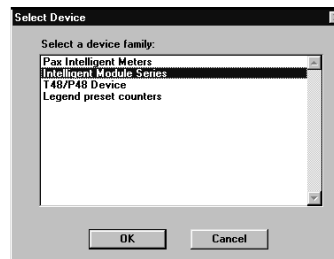

You will be prompted to select the proper device,

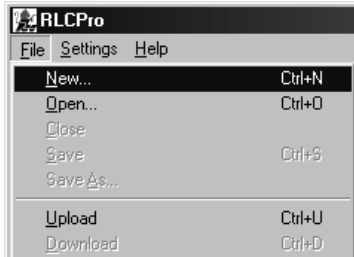

Use the FILE pull-down menu to select a NEW file.

and then the model.

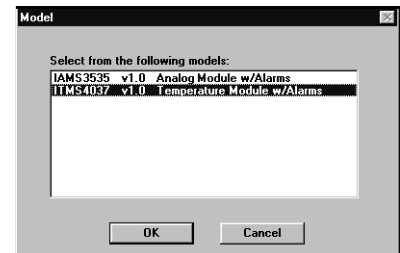

## STEP 4 PROGRAMMING THE INPUT

The ITMS receives a temperature sensor input, converts it to a raw digital value, and stores this number in the ADC Value (register 40001). This number is scaled into degrees, and a programmable Offset Value (register 40012), that can be used for sensor correction, is applied. The result is stored as the Temperature Value (register 40002). It is also stored in the IEEE 754 Standard 32-bit floating decimal format (register 40003 and 40004). The non-scaled ADC, the scaled Process Temperature Value, or the Floating Point Value may be accessed for the purpose of monitoring the input level.

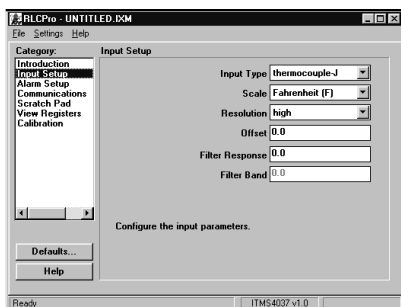
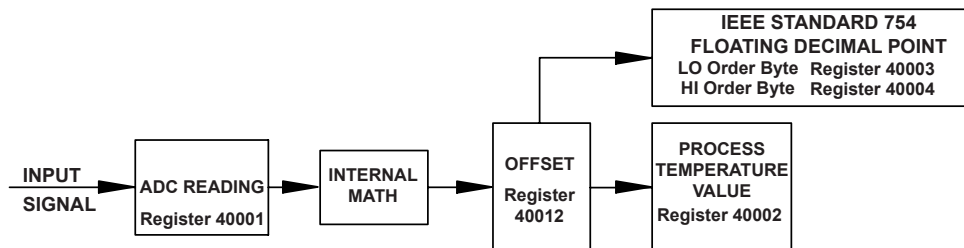

**Input Type:** Select the proper input type from the pull down menu.

**Scale:** Select Fahrenheit or Celsius. In linear millivolt or resistance modes, this has no effect.

**Resolution:** For thermocouple, RTD, or linear resistance modes, low resolution selects whole degrees or ohms. In these same modes, high resolution selects tenth of degrees or ohms. In linear mV mode, low selects hundredths of mV, and high selects thousandths of mV.

**Offset:** The Offset value can be used as a sensor correction value.

**Filter Response:** The Filter Response is a time constant, in tenth of second increments, that is used to stabilize an erratic input. The Process Value stabilizes to 99% of the final value within approximately 5 time constants. A value of '0' disables digital filtering.

**Filter Band:** Filter Band is a value expressed in Temperature (degrees or tenths) units. When a fluctuating signal remains within the band value, the Digital Filter is active, and therefore stabilizes the Process Temperature Value. When a fluctuating signal exceeds the Filter Band value, the Digital Filter is momentarily disabled to allow for quick response to valid process changes. Once the signal variation is less than the Filter Band value, the Digital Filter is reactivated.

# STEP 5 PROGRAMMING THE ALARMS

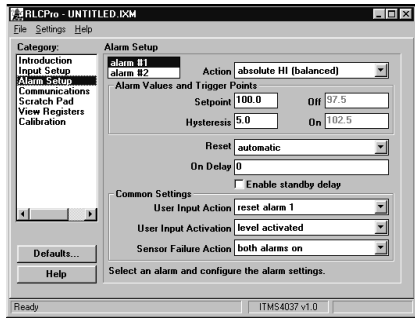

**Action:** Alarm 1 can be programmed for 5 modes of operation, Alarm 2 has 9 possible modes. See Setpoint Alarm figures for illustration.

**Manual:** In Manual mode, the Alarms are forced on and off by writing '0' or '1' to the appropriate MODBUS register (Alarm 1 state = 40027, Alarm 2 state = 40028). The alarms are configured for this action from the factory. In this mode, the alarms will not respond to their setpoint or hysteresis values.

**Absolute HI:** (with balanced or unbalanced hysteresis) The Alarm energizes when the Temperature Value exceeds the Setpoint Limit Value.

**Absolute LO:** (with balanced or unbalanced hysteresis) The Alarm energizes when the Temperature Value falls below the Setpoint Limit Value.

**Deviation HI, Deviation LO, Band Inside or Outside:** In these modes, Alarm 2 "tracks" Alarm/Setpoint 1.

**Setpoint:** The alarm Setpoint value, entered in degrees. If the ITMS is programmed for mV or resistance modes, then the Setpoint is in mV or Ohms, respectively.

**Hysteresis:** Hysteresis is used to eliminate output chatter. The Hysteresis Amount is the difference between the points where an Alarm will turn on and turn off. In Unbalanced modes, the alarm turns on at the Setpoint, and turns off at Setpoint minus hysteresis for HI alarms, and Setpoint plus hysteresis for LO alarms. In Balanced modes, the hysteresis is evenly divided above and below the Setpoint value. (See the Setpoint Alarm Figures.)

*Note: The Setpoint, along with the Hysteresis, MUST NOT produce a "trigger point" higher than 32,000, or less than -32,000. (See the Setpoint Alarm Figures.)*

**Trigger Points:** Trigger Points are the Process Values where the alarm state changes. Their values cannot be entered directly, but are shown as a reference in the SFIMS software. The Setpoint Value, Hysteresis Value, and Setpoint Alarm Type determine the trigger points. With Deviation or Band modes, Setpoint 1 and Setpoint 2 are combined to determine the trigger points. Trigger Points cannot be greater than +32000 or less than -32000. If these limits are exceeded, the alarm is disabled and an alarm threshold over range error is set. The Trigger Points can be outside the Temperature Value range for a given sensor type without receiving an error, but the alarm will not change state for that trigger point.

**Reset:** The alarms can be programmed for Automatic or Latched. In Automatic mode, an energized alarm turns off by itself once the Process Value leaves the alarm region. In Latched mode, an energized alarm requires a reset from the User input, or a serial reset command. This is done by writing a '0' to the appropriate MODBUS register. (Alarm 1 state = 40027, Alarm 2 state = 40028)

**On Delay:** The time, in whole second increments, that the alarm will take to energize when the Process Value enters into an alarm region.

**Enable Standby Delay:** Standby prevents nuisance (typically low level) alarms after a power up. After powering up the unit, the temperature must leave the alarm region. Once this has occurred, the standby is disabled, and the alarm responds normally until the next module power up.

**User Input Action:** The User Input can be programmed to Reset, or Set, either Alarm 1, Alarm 2, or both. The User Input is activated when terminal 6 is pulled low. (Connected to the Common terminal 12.)

**User Input Activation:** The User Input can be programmed to respond as a Level (maintained) or Edge (momentary) input. See the User Input Mode Operation Table below.

**Sensor Failure Action:** This setting allows different alarm responses when the temperature sensor fails. The ITMS can be programmed to turn one or both alarms on or off.

## USER INPUT MODE OPERATION

INPUT ACTION	INPUT ACTIVATION	AUTOMATIC ALARM		LATCHED ALARM	
		IN ALARM REGION	OUTSIDE ALARM REGION	IN ALARM REGION	OUTSIDE ALARM REGION
Reset	Edge	Resets and puts the alarm in Standby mode; resets alarm if in Hysteresis band	No action	Resets and puts the alarm in Standby mode; resets alarm if in Hysteresis band	Resets alarm if on
Set	Edge	No action	No action	No action	Sets alarm latched
Reset	Level	Resets alarm while input is active, resumes normal operation when input is inactive; resets alarm if in Hysteresis band	No action	Resets alarm while input is active, resumes normal operation when input is inactive; resets alarm if in Hysteresis band	Resets alarm if on
Set	Level	No action	Sets alarm while input active, resumes normal operation when input is inactive	No action	Sets alarm latched

## SETPOINT ALARM FIGURES

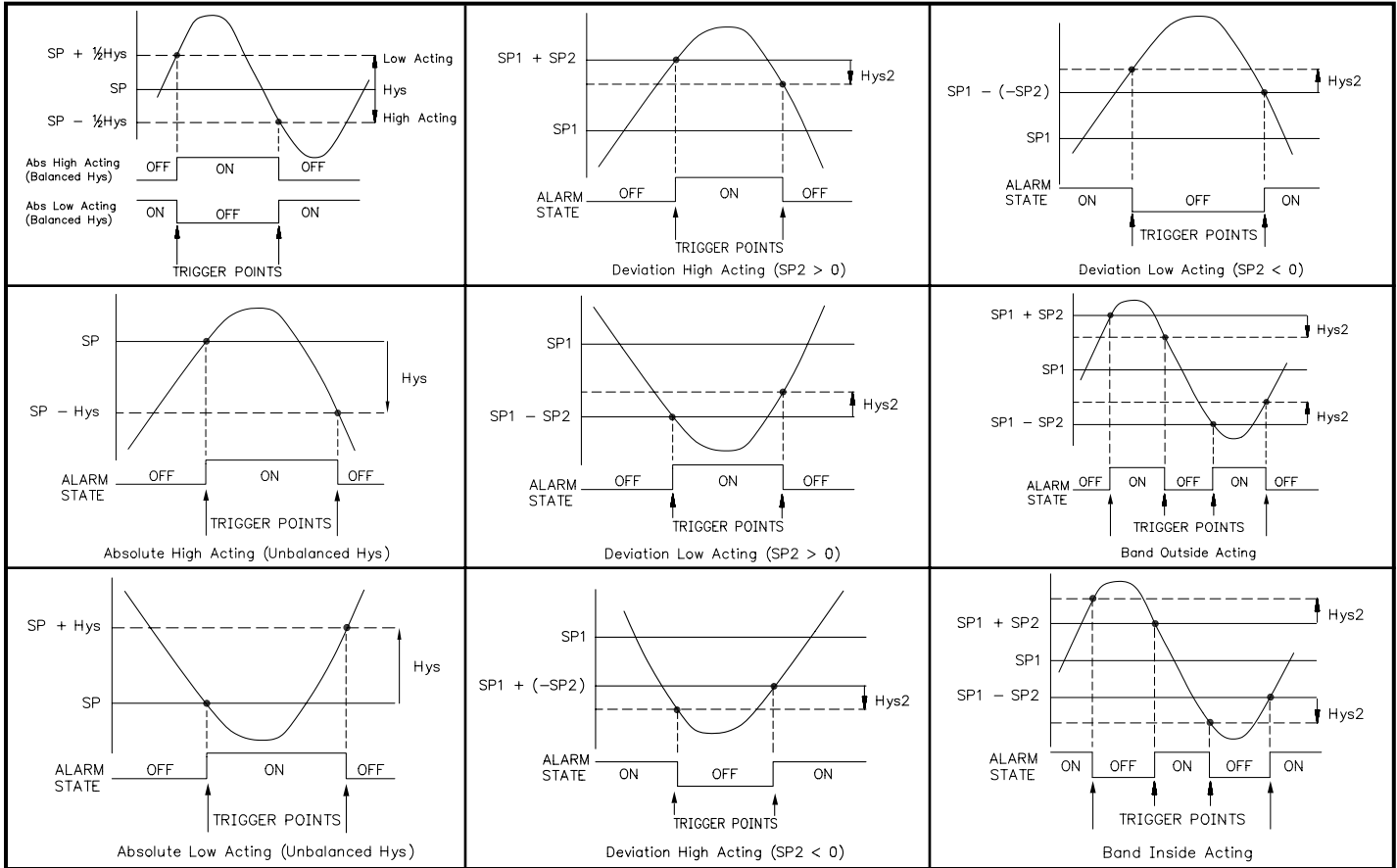

## STEP 6 PROGRAMMING THE ITMS COMMS PORT

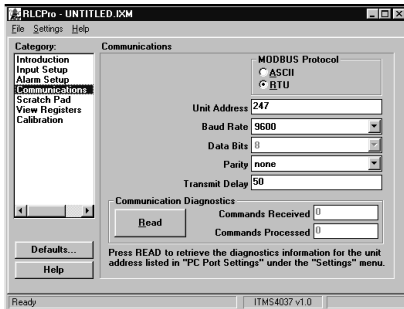

**MODBUS Protocol:** RTU or ASCII

**Unit Address:** 1-247

**Baud Rate:** 300, 600, 1200, 2400, 4800, 9600, 19200, or 38400

**Data Bits:** 7 or 8

**Parity:** odd, even, or none

**Transmit Delay:** Programmable from 1-255 milliseconds. The Transmit Delay is the time the ITMS waits to respond to a serial command, UNLESS the values in the table are larger.

*Note: If the communication settings are changed and then a download is performed, the module will now respond to the new settings. Any further attempts to communicate to the module must target the new address, with the new settings. If you do not know or cannot recall the ITMS settings, they can be reset to factory defaults. Connect the Serial Default terminal to Common, and cycle power. The Defaults button in the SFIMS software will update the category display to these settings.*

BAUD	RTU	ASCII
38400	2 msec.	2 msec.
19200	3 msec.	2 msec.
9600	5 msec.	2.3 msec.
4800	9 msec.	4.6 msec.
2400	17 msec.	9.2 msec.
1200	33 msec.	18.4 msec.
600	65 msec.	36.7 msec.
300	129 msec.	73.4 msec.

**Communications Diagnostics:** The Communications Diagnostics function can be used to troubleshoot systems that are experiencing communication errors. Press the Read button to retrieve the diagnostics information. The Commands Received and the Commands Processed values are automatically reset when the values are read, and at each unit power-up.

**Commands Received:** The number of messages received that started with the unit's own address.

**Commands Processed:** The number of "good" messages received. A "good" message is considered one that contained the correct unit address, parity, and checksum (CRC or LRC).

## STEP 7 PC PORT CONFIGURATION



Go to the SETTINGS pull-down menu, and select PC PORT SETTINGS.

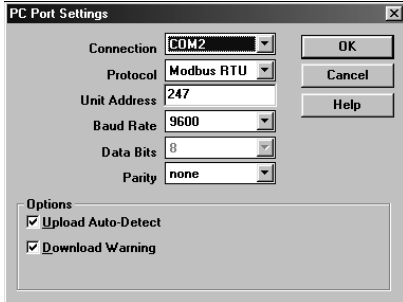

The Communications Settings window allows you to set up the software properly to perform a download.

**Connection:** Select the computer port (COMM 1-4) that the ITMS is connected to.

*Note: The following settings must match the ITMS. If you do not know or cannot recall the ITMS settings, they can be reset back to factory defaults. Simply jumper the Serial Default terminal to Common, and cycle power. The serial settings will default to RTU mode, 9600 baud, 8 data bits, No parity, with an address of 247.*

**Protocol:** RTU or ASCII

**Unit Address:** 1-247

**Baud Rate:** 300, 600, 1200, 2400, 4800, 9600, 19200, 38400

**Data Bits:** 7 or 8

**Parity:** odd, even, or none

Connect the ITMS to the computer with the CBPRO007 interface cable (or any suitable RS232/RS485 converter). Apply 18-36 VDC to the supply terminals of the ITMS.

*Note: The CBPRO007 download cable DOES NOT typically require power. In most cases it will derive its power from the PC. If communications can not be established, follow the troubleshooting guide. If it is determined that the converter requires power, attach a 12 VDC power supply to the VDC and common terminals of the cable.*

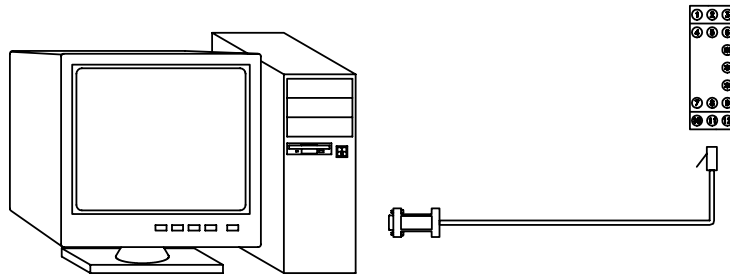

## STEP 8 DOWNLOADING



Go to the FILE pull-down menu, and select DOWNLOAD.

The following screen prompts you to ensure that the proper file is downloaded to the correct module. Click "OK" to continue.

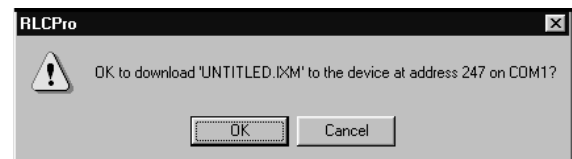

## STEP 9 SCRATCH PAD MEMORY

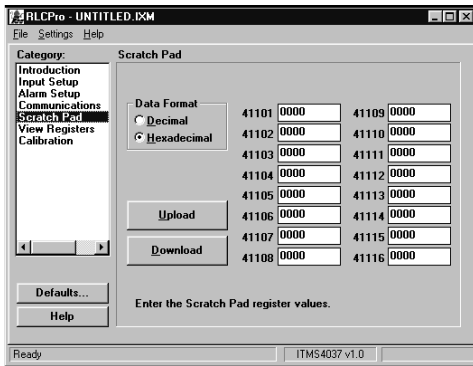

The Scratch Pad category can be used to read or write to the Scratch Pad memory locations (41101-41116). The Scratch Pad locations can be used to store user information.

**Data Format:** Allows registers to be viewed in decimal or hexadecimal format.

**Upload:** The Upload button causes SFIMS software to read the Scratch Pad registers from the module.

**Download:** The Download button causes SFIMS software to write to the Scratch Pad registers in the module.

*Note: Downloading new values to the module Scratch Pad locations overwrites the information that is currently stored in those registers.*

## STEP 10 VIEW REGISTERS

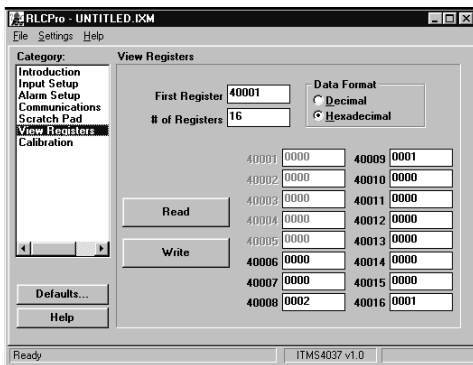

The View Registers category can be used as a method of diagnostics. Use the ITMS Register Table as a reference of register assignments and data.

**First Register:** This specifies the first, or only, register to be read in a block.

**# of Registers:** This is the length of the block to be read. The module supports block read and write commands up to 16 registers in length.

**Data Format:** Allows registers to be viewed in decimal or hexadecimal format.

**Read:** Clicking the Read button causes SFIMS software to read the selected register from the module.

**Write:** Clicking the Write button causes SFIMS software to write the selected registers to the module.

*Note: The Write button overwrites the existing register values, and may change the module setup and operation.*

## STEP 11 CALIBRATION

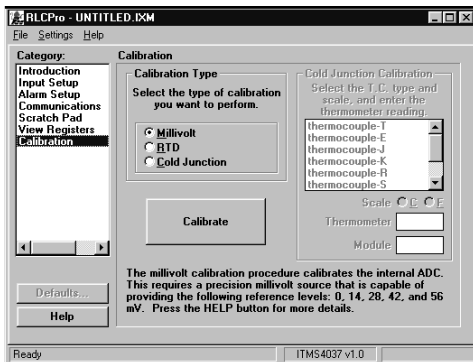

The ITMS is fully calibrated from the factory. Recalibration is recommended every two years. Each range has its own internal references that are recalled when the range is selected. This allows independent calibration for each range. All calibration settings are stored in the E<sup>2</sup>PROM. Calibration may be performed by using SFIMS software or MODBUS commands.

RTD and CJ calibrations are dependent on the millivolt calibration and, therefore, must be performed after a millivolt calibration has been completed. RTD or CJ calibration may be performed independently of the millivolt calibration.

**Calibration Type:** This specifies the type of calibration to be performed.

**Cold Junction Calibration:**

**TC Type:** This selects the type of TC that is being used to calibrate the cold junction.

**Scale:** This selects the scale in which the Thermometer temperature is entered and the Module temperature is displayed.

**Thermometer:** Enter the reference thermometer temperature here.

**Module:** This displays the ITMS process temperature value after a cold junction calibration is completed to verify the accuracy.

**Calibrate:** The Calibrate button initiates the calibration process after the appropriate settings are selected.

*Note: Millivolt calibration requires a precision voltage source with an accuracy of 0.025% or better. Allow the ITMS to warm up for 30 minutes minimum and follow the manufacturer's warm-up recommendations for the calibration source. RTD calibration requires a 0.1% precision 300 ohm resistor. CJ calibration should be performed with a TC of known accuracy of types T, E, J, K, C or N only. When using SFIMS for calibration, select the type of calibration to be performed, and press the Calibrate button. Follow the calibration procedures in the software.*

# TROUBLESHOOTING

PROBLEM	CAUSE	REMEDIES
Green LED will not light	Module power	Check module power connections and voltage level
Process Value not changing	Input signal	Check input signal connections and signal level
Process Value not changing or incorrect	Incorrect scaling	Check input setup, scaling values, and re-download
Alarms disabled	Alarm threshold over range*; checksum error; Input over/under range; open or shorted probe*; calculated results over +32000 or -32000; in Calibration Mode	Adjust alarm Setpoint and Hysteresis to ensure trigger point is within -32000 to +32000 (See Alarm setup). For other possible causes, see the remaining remedies
Process Value stays at 32001 or -32001	Input over or under range* due to: Wrong TC, or RTD Incorrect input type	Check input level Check input type, and re-download
Process Value stays at 32002	Open TC or RTD:*	Check input signal connections and probe
Process Value stays at -32002	Shorted RTD:*	Check input signal connections and probe
Process Value stays at +32003 or -32003	Calculated Temp. value over +32000 or -32000	Check offset value, Register 40012
Process Value stays at 32100, Flashing LEDs, alarms disabled	Parameter checksum*, loss of parameter settings Calibration checksum*	Re-download SFIMS file (reconfigures each parameter) Perform calibration procedure
Will not communicate (Green LED not flashing)	Incorrect serial settings (ITMS port) Incorrect serial settings (computer port) Incorrect wiring	Verify ITMS communications setup Go to pull down menu SETTINGS, PC PORT SETTINGS Try switching A+ and B- lines Provide a common connection
<p><i>NOTE: The ITMS' serial settings must match the device that it is communicating with. If you do not know or cannot recall the ITMS settings, they can be reset back to factory defaults. Simply jumper the Serial Default terminal to Common, and cycle power. The serial settings will default to RTU mode, 9600 baud, 8 data bits, no parity, with an address of 247.</i></p>		

\* Can be monitored by accessing coils 9-16, or register 40025.  
For further technical assistance, contact technical support.

## INSTALLATION

The unit is equipped with a universal mounting foot for attachment to standard DIN style mounting rails, including G profile rail according to EN50035 - G32, and top hat (T) profile rail according to EN50022 - 35 x 7.5 and 35 x 15. The unit should be installed in a location that does not exceed the maximum operating temperature and provides good air circulation. Placing the unit near devices that generate excessive heat should be avoided.

### G Rail Installation

To install the ITMS on a "G" style DIN rail, angle the module so that the upper groove of the "foot" catches under the lip of the top rail. Push the module toward the rail until it snaps into place. To remove a module from the rail, push up on the bottom of the module while pulling out and away from the rail.

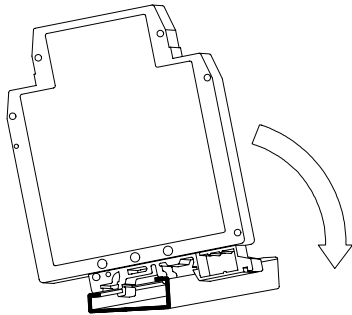

### T Rail Installation

To install the ITMS on a "T" style rail, angle the module so that the top groove of the "foot" is located over the lip of the top rail. Push the module toward the rail until it snaps into place. To remove a module from the rail, insert a screwdriver into the slot on the bottom of the "foot", and pry upwards on the module until it releases from the rail.

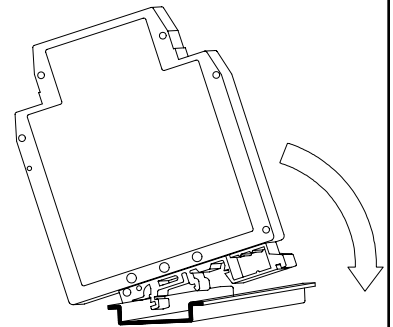

## APPLICATION

A chemical company wanted to remotely monitor the temperature of several holding tanks. Using the ITMS, the customer was able to receive, interpret, and store the temperature readings via standard thermocouples. To provide a remote display, the customer chose a Red Lion Paradigm HMI (Human Machine Interface). The HMI communicates with the ITMS modules and displays the information graphically, providing an intuitive interface. As an added benefit, the ITMS alarm setpoints can be adjusted from the HMI, while providing reliable local alarm outputs.

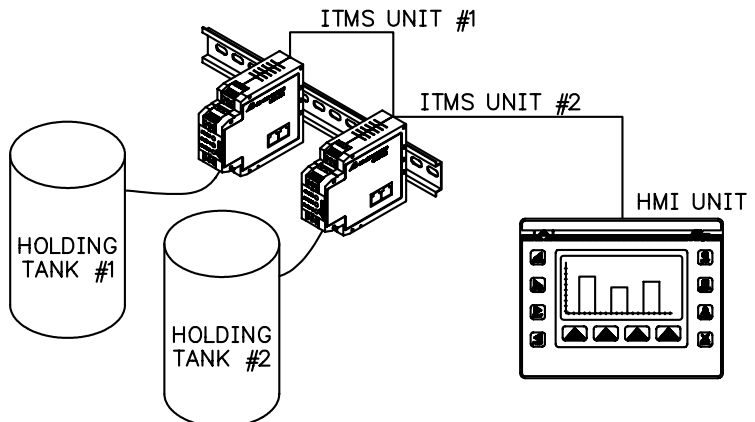

# MODBUS INFORMATION

The remaining sections of this bulletin list ITMS Register Format information and MODBUS conformity.

## MODBUS SUPPORTED FUNCTION CODES

### FC01: Read Coils

1. Valid coil addresses are 1-16.
2. Only 16 coils can be requested at one time.
3. Block starting point can not exceed coil 16.

### FC05: Force Single Coil

1. Valid write (force) coil addresses are 1-10.
2. <8001>HEX is echoed back that the coil did not change during the request to write to a read only coil.

### FC15: Force Multiple Coils

1. Valid write (force) coil addresses are 1-10.
2. Block starting point can not exceed coil 10.
3. If a multiple write includes read only coils, then only the write coils will change.

### FC03: Read Holding Registers

1. Valid addresses are 40001-40029, 41001-41010, 41101-41116.
2. Only 16 registers can be requested at one time.
3. Block starting point can not exceed the register boundaries.
4. <8000>HEX is returned in registers beyond the boundaries.
5. Holding registers are a mirror of Input registers.

### FC06: Preset Single Register

1. Valid write (preset) addresses are 40006-40029, 41101-41116.
2. <8001>HEX is echoed back that the register did not change during the request to write to a read only register.
3. If the write value exceeds the register limit (see Register Table), then that register value changes to its exceeded high or low limit. It is also returned in the response.

### FC16: Preset Multiple Registers

1. Valid write (force) register addresses are 40006-40029, 41101-41116.
2. No response is given with an attempt to write to more than 16 registers at a time.
3. Block starting point can not exceed the read and write boundaries.
4. If a multiple write includes read only registers, then only the write registers will change.
5. If the write value exceeds the register limit (see Register Table), then that register value changes to its exceeded high or low limit.

### FC04: Read Input Registers

1. Valid addresses are 30001-30029, 31001-31010, 31101-31116.
2. Only 16 registers can be requested at one time.
3. Block starting point can not exceed register boundaries.
4. <8000>HEX is returned in registers beyond the boundaries.
5. Input registers are a mirror of Holding registers.

### FC08: Diagnostics

The following is sent upon FC08 request:

Unit Address, 08 (FC code), 04 (byte count), "Total Comms" 2 byte count, "Total Good Comms" 2 byte count, checksum of the string.  
"Total Comms" is the total number of messages received that were addressed to the ITMS. "Total Good Comms" is the total messages received by the ITMS with good address, parity and checksum. Both counters are reset to 0 upon response to FC08.

### FC17: Report Slave ID

The following is sent upon FC17 request:

Unit Address, 17 (FC code), RLC-ITMS4037, 0100 (for code version 1.00), 16 (number of read supported registers), 16 (number of writes supported registers), 16 (number of registers available for GUID/ Scratch pad memory), checksum of the string.

The following is the HEX of the above (with unit address of 247):

<F7><11><14><52><4C><43><2D><49><54><4D><53><34><30><33>  
<37><01><00><00><10><00><10><00><10><8D><9F>

## SUPPORTED EXCEPTION CODES

### 01: Illegal Function

Issued whenever the requested function is not implemented in the unit.

### 02: Illegal Data Address

Issued whenever an attempt is made to access a single register or coil that does not exist (outside the implemented space) or to access a block of registers or coils that falls completely outside the implemented space.

### 03: Illegal Data Value

Issued when an attempt is made to read or write more registers or coils than the unit can handle in one request.

### 07: Negative Acknowledge

Issued when a write to coil or register is attempted with an invalid string length.

## CHECKSUM ERRORS

1. Calibration checksum covers the E<sup>2</sup> PROM that contains calibration values for all ranges. When a calibration checksum error occurs, coil 10 becomes a 1. (See Coils Table)
2. Parameter checksum covers the E<sup>2</sup> PROM that contains the stored Holding register settings. When a parameter checksum error occurs, coil 9 becomes a 1. (See Coils Table)
3. All of the LEDs will flash as long as either error occurs.
4. The alarms are disabled as long as either error occurs.
5. Either error can be cleared or activated manually by writing to the appropriate coil. (This does not correct the reason for the error. It may be necessary to reconfigure or calibrate.)
6. Both checksums are verified at power up.

## CALIBRATION

Calibration may be performed by using SFIMS software, or MODBUS commands. Review Calibration explanation in Step 11, before performing these steps.

### mV Calibration

1. Connect the signal source to proper ITMS terminals.
2. To set Input Type, enter 9 into register 40008.
3. To start calibration, enter <7777> HEX into register 40029.
4. To start ADC calibration, enter <0001> HEX into register 40029.
5. Apply the appropriate voltage and enter the corresponding <>HEX value into register 40029 for each range to be calibrated.  
0 mV <0002>, 14 mV <0003>, 28 mV <0004>, 42 mV <0005>, 56 mV <0006>
6. To save the values and end calibration, enter <0000> HEX into register 40029.

### CJ Calibration

*Note: In this procedure, write functions are performed in HEX and a write to a register is monitored by a read in a different register.*

1. Connect the thermocouple probe source to the proper ITMS terminals. (Types T, E, J, K, N and C only).
2. To set Input Type, enter connected TC type into register 40008.
3. To set Scale, enter 1 for °C or 0 for °F into register 40006.
4. To set High Resolution, enter 1 into register 40009.
5. Place an external reference thermometer probe at the end of the ITMS probe. The two probes should be shielded from air movement and allow sufficient time to equalize in temperature. (As an alternative, the ITMS probe may be placed in a calibration bath of known temperature.)
6. To start calibration, enter <7777> HEX into register 40029.
7. To start CJ calibration, enter <0010> HEX into register 40029.
8. Read the Process Temperature Value register 40002 (Read as an Integer).
9. Subtract the external reference reading from the Process Temperature Value register 40002 reading. Adjust the results to hundredths position, drop decimal point, and maintain the results sign. (If the difference is -2.0 degrees, then adjust to -2.00 and remove decimal point yielding a value of -200.)
10. Enter <0011> HEX into register 40029.
11. Add the value from step 9 (maintain the sign) to the value existing in register 40007 (Read as an Integer).
12. If necessary, continue to adjust register 40007 value until the Process Temperature Value register 40002 matches the external reference reading.
13. To save the values and end calibration, enter <0000> HEX into register 40029.

### RTD Calibration

1. Connect precision 300 ohm resistor to terminals 11 & 12. Short terminals 10 & 11.
2. To set Input Type, enter 13 (Integer) or <000D> HEX into register 40008.
3. To start calibration, enter <7777> HEX into register 40029.
4. To start 0 ohm RTD calibration, enter <0015> HEX into register 40029.
5. Apply 0 ohms by shorting terminals 11 & 12 for 10 seconds.
6. To start 300 ohm RTD calibration, enter <0016> HEX into register 40029.
7. Apply 300 ohms by removing short from terminal 11 for 10 seconds.
8. To save the values and end calibration, enter <0000> HEX into register 40029.

## REGISTER TABLE

The below limits are shown as Integers or HEX <> values. Read and write functions can be performed in either Integers or HEX as long as the conversion was done correctly. Negative numbers are represented by two's complement.

REGISTER ADDRESS *	REGISTER NAME	LOW LIMIT†	HIGH LIMIT†	ACCESS	COMMENTS
40001	ADC reading	N/A	N/A	Read Only	ADC (Analog to Digital Converter) reading of present input level.
40002	Process Temperature Value	N/A	N/A	Read Only	Process Value (with scale and offset) of present input level.
40003	Floating Point LO	N/A	N/A	Read Only	IEEE Standard 754 Floating Decimal Point, low order of Temperature Value. (Allows 32 bit accuracy for external monitoring.)
40004	Floating Point HI	N/A	N/A	Read Only	IEEE Standard 754 Floating Decimal Point, high order of Temperature Value. (Allows 32 bit accuracy for external monitoring.)
40005	User Input Pin State	N/A	N/A	Read Only	0 = Active, 1 = Inactive.
40006	Temperature Scale	0	1	Read/Write	0 = °F, 1 = °C.
40007	CJ Temp	-32000	32000	Read/Write	Cold Junction calibration temp (1 = 0.01°C).
40008	Input Type	0	13	Read/Write	See Input Type Register Table.
40009	High Resolution	0	1	Read/Write	0 = 1 degree, 1 = 0.1 degree.
40010	Filter Band	0	32000	Read/Write	See Filter Band explanation.
40011	Filter Response Time	0	1000	Read/Write	See Filter Response Time explanation (1 = 0.1 second).
40012	Offset Value	-32000	32000	Read/Write	See Offset explanation.
40013	User Input Action	<0000>	<0015>	Read/Write	See User Input Action Register Table.
40014	Alarm 2 Action	<0000>	<0038>	Read/Write	See Alarm 1 & 2 Action Register Table.
40015	Setpoint 2 Value	-32000	32000	Read/Write	Alarm 2 setpoint value based on Process Value.
40016	Alarm 2 Hysteresis	1	32000	Read/Write	Alarm 2 hysteresis value based on Process Value.
40017	Alarm 2 Delay	0	32000	Read/Write	Alarm 2 delay trip on time (1 = 1 second).
40018	Alarm 1 Action	<0000>	<0034>	Read/Write	See Alarm 1 & 2 Action Register Table.
40019	Setpoint 1 Value	-32000	32000	Read/Write	Alarm 1 setpoint value based on Process Value.
40020	Alarm 1 Hysteresis	1	32000	Read/Write	Alarm 1 hysteresis value based on Process Value.
40021	Alarm 1 Delay	0	32000	Read/Write	Alarm 1 delay trip on time (1 = 1 second).
40022	Sensor Failure Action	0	3	Read/Write	See Sensor Failure Action For Alarm State Table.
40023	Transmit Delay	1	255	Read/Write	Delay before serial transmission (1 = 1 msec). See Transmit Delay Explanation.
40024	Node (Unit) Address	1	247	Read/Write	Node serial ITMS address.
40025	Error Coils	<0000>	<0003>	Read/Write	Mirror of Coils 9-16. See Coil Table.
40026	Comm. Coils	<0020>	<00FF>	Read/Write	Mirror of Coils 1-8. See Coil Table and Communications Table.
40027	Alarm 1 State	0	1	Read/Write	Alarm 1 state (1 = on).
40028	Alarm 2 State	0	1	Read/Write	Alarm 2 state (1 = on).
40029	Factory Calibration	<0000>	<7777>	Read/Write	See MODBUS Calibration explanation.
41001- 41010	Slave ID	See FC17.	See FC17.	Read Only	ITMS-4037, 0100 (ver. 1.00), 16 reads, 16 writes, 16 scratch. The version value could be higher.
41101- 41116	GUID/Scratch	<0000>	<FFFF>	Read/Write	This area is for the user to store any related information. This register area does not affect ITMS operations.

\* For Input Registers, replace the 4xxxx with a 3xxxx in the above register address. The 3xxxx are a mirror of the 4xxxx Holding Registers.

† An attempt to exceed a limit will set the register to its high or low limit value.

## COILS TABLE (COMMUNICATION AND ERRORS)

COIL ADDRESS	COIL NAME	ACCESS	COMMENTS
1	Baud B0	Read/Write	See Communication Register and Coils Table.
2	Baud B1	Read/Write	See Communication Register and Coils Table.
3	Baud B2	Read/Write	See Communication Register and Coils Table.
4	Parity B3	Read/Write	See Communication Register and Coils Table.
5	Parity B4	Read/Write	See Communication Register and Coils Table.
6	Data Bits B5	Read/Write	See Communication Register and Coils Table.
7	Mode B6	Read/Write	See Communication Register and Coils Table.
8	Change B7	Read/Write	"1" = Change ITMS communications to above settings.
9	P. Checksum Error	Read/Write	"1" = Parameter checksum error, disables alarms, causes flashing LEDs.
10	C. Checksum Error	Read/Write	"1" = Calibration checksum error, disables alarms, causes flashing LEDs.
11	AL 1 Over Range	Read Only	"1" = Alarm 1 Threshold over range, disables alarms, causes no LED indication.
12	AL 2 Over Range	Read Only	"1" = Alarm 2 Threshold over range, disables alarms, causes no LED indication.
13	Open Input	Read Only	"1" = Open RTD or TC, causes Process Temp. Value to be 32002, disables alarms, causes no LED indication.
14	Over Range	Read Only	"1" = Over Range, causes Process Temp. Value to be 32001, disables alarms, causes no LED indication.
15	Under Range	Read Only	"1" = Under Range, causes Process Temp. Value to be -32001, disables alarms, causes no LED indication.
16	Shorted RTD	Read Only	"1" = Shorted RTD, causes Process Temp. Value to be -32002, disables alarms, causes no LED indication.

Coils 1-7 mirror register 40026 and Coils 9-16 mirror register 40025.

**INPUT TYPE REGISTER (40008) TABLE**

MODE	TYPE	MODE	TYPE	MODE	TYPE
0	Tc - T	5	Tc - S	10	RTD - 385
1	Tc - E	6	Tc - B	11	RTD - 392
2	Tc - J	7	Tc - N	12	RTD - 672
3	Tc - K	8	Tc - C	13	LIN Ohms
4	Tc - R	9	LIN mV		

**USER INPUT ACTION REGISTER (40013) TABLE**

MODE	ACTION	ALARM	INPUT ACTIVATION
<0000>	Reset	1	Level (Maintained)
<0001>	Reset	2	Level (Maintained)
<0002>	Reset	1 & 2	Level (Maintained)
<0003>	Set	1	Level (Maintained)
<0004>	Set	2	Level (Maintained)
<0005>	Set	1 & 2	Level (Maintained)
<0010>	Reset	1	Edge (Momentary)
<0011>	Reset	2	Edge (Momentary)
<0012>	Reset	1 & 2	Edge (Momentary)
<0013>	Set	1	Edge (Momentary)
<0014>	Set	2	Edge (Momentary)
<0015>	Set	1 & 2	Edge (Momentary)

**SENSOR FAILURE ACTION REGISTER (40022) TABLE FOR ALARM STATE CONDITION**

MODE	ALARM 1	ALARM 2
0	Off	Off
1	On	On
2	Off	On
3	On	Off

**ALARM 1 (40018) & 2 (40014) ACTION REGISTER TABLE**

Stand By	Latched Off=Auto	B7	B6	B5	B4	2nd Nibble HEX
off	off	0	0	0	0	<0 >
off	on	0	0	0	1	<1 >
on	off	0	0	1	0	<2 >
on	on	0	0	1	1	<3 >

ACTION	MODE	ALARMS	B3	B2	B1	B0	1st Nibble HEX
Manual	0	1 2	0	0	0	0	< 0>
Absolute Hi, balanced	1	1 2	0	0	0	1	< 1>
Absolute Lo, balanced	2	1 2	0	0	1	0	< 2>
Absolute Hi, unbalanced	3	1 2	0	0	1	1	< 3>
Absolute Lo, unbalanced	4	1 2	0	1	0	0	< 4>
Deviation Hi	5	2	0	1	0	1	< 5>
Deviation Lo	6	2	0	1	1	0	< 6>
Band Outside	7	2	0	1	1	1	< 7>
Band Inside	8	2	1	0	0	0	< 8>

**Examples:**

Alarm 1 (40018):

Stand-by off, Latch on = 0 0 0 1 <1 >

Absolute Lo, Balanced = 0 0 1 0 <2 >  
<12>

Alarm 2 (40014):

Stand-by on, Latch off = 0 0 1 0 <2 >

Band Outside = 0 1 1 1 <7 >  
<27>

See Setpoint Alarm Figures, Page 5, for illustrations of alarm operation.

**COMMUNICATIONS REGISTER (40026) AND COILS 1-8 TABLE**

Mode	Parity	Baud	Coil 8 B7*	Coil 7 B6	Coil 6 B5	Coil 5 B4	Coil 4 B3	Coil 3 B2	Coil 2 B1	Coil 1 B0	Coil 8 =0 HEX	Coil 8 =1 HEX
RTU	8N1,2	300	0 / 1	0	1	0	0	0	0	0	<20>	<A0>
RTU	8N1,2	600	0 / 1	0	1	0	0	0	0	1	<21>	<A1>
RTU	8N1,2	1200	0 / 1	0	1	0	0	0	1	0	<22>	<A2>
RTU	8N1,2	2400	0 / 1	0	1	0	0	0	1	1	<23>	<A3>
RTU	8N1,2	4800	0 / 1	0	1	0	0	1	0	0	<24>	<A4>
RTU	8N1,2	9600	0 / 1	0	1	0	0	1	0	1	<25>	<A5>
RTU	8N1,2	19200	0 / 1	0	1	0	0	1	1	0	<26>	<A6>
RTU	8N1,2	38400	0 / 1	0	1	0	0	1	1	1	<27>	<A7>
RTU	8E1	300	0 / 1	0	1	0	1	0	0	0	<28>	<A8>
RTU	8E1	600	0 / 1	0	1	0	1	0	0	1	<29>	<A9>
RTU	8E1	1200	0 / 1	0	1	0	1	0	1	0	<2A>	<AA>
RTU	8E1	2400	0 / 1	0	1	0	1	0	1	1	<2B>	<AB>
RTU	8E1	4800	0 / 1	0	1	0	1	1	0	0	<2C>	<AC>
RTU	8E1	9600	0 / 1	0	1	0	1	1	0	1	<2D>	<AD>
RTU	8E1	19200	0 / 1	0	1	0	1	1	1	0	<2E>	<AE>
RTU	8E1	38400	0 / 1	0	1	0	1	1	1	1	<2F>	<AF>
RTU	8O1	300	0 / 1	0	1	1	1	0	0	0	<38>	<B8>
RTU	8O1	600	0 / 1	0	1	1	1	0	0	1	<39>	<B9>
RTU	8O1	1200	0 / 1	0	1	1	1	0	1	0	<3A>	<BA>
RTU	8O1	2400	0 / 1	0	1	1	1	0	1	1	<3B>	<BB>
RTU	8O1	4800	0 / 1	0	1	1	1	1	0	0	<3C>	<BC>
RTU	8O1	9600	0 / 1	0	1	1	1	1	0	1	<3D>	<BD>
RTU	8O1	19200	0 / 1	0	1	1	1	1	1	0	<3E>	<BE>
RTU	8O1	38400	0 / 1	0	1	1	1	1	1	1	<3F>	<BF>

\* When reading register 40026, B7 will be a 0. When writing (changing ITMS communications to the new setting), change B7 to a 1.

**COMMUNICATIONS REGISTER (40026) AND COILS 1-8 TABLE (continued)**

Mode	Parity	Baud	Coil 8 B7 *	Coil 7 B6	Coil 6 B5	Coil 5 B4	Coil 4 B3	Coil 3 B2	Coil 2 B1	Coil 1 B0	Coil 8 =0 HEX	Coil 8 =1 HEX
ASCII	7N2	300	0 / 1	1	0	0	0	0	0	0	<40>	<C0>
ASCII	7N2	600	0 / 1	1	0	0	0	0	0	1	<41>	<C1>
ASCII	7N2	1200	0 / 1	1	0	0	0	0	1	0	<42>	<C2>
ASCII	7N2	2400	0 / 1	1	0	0	0	0	1	1	<43>	<C3>
ASCII	7N2	4800	0 / 1	1	0	0	0	1	0	0	<44>	<C4>
ASCII	7N2	9600	0 / 1	1	0	0	0	1	0	1	<45>	<C5>
ASCII	7N2	19200	0 / 1	1	0	0	0	1	1	0	<46>	<C6>
ASCII	7N2	38400	0 / 1	1	0	0	0	1	1	1	<47>	<C7>
ASCII	7E1	300	0 / 1	1	0	0	1	0	0	0	<48>	<C8>
ASCII	7E1	600	0 / 1	1	0	0	1	0	0	1	<49>	<C9>
ASCII	7E1	1200	0 / 1	1	0	0	1	0	1	0	<4A>	<CA>
ASCII	7E1	2400	0 / 1	1	0	0	1	0	1	1	<4B>	<CB>
ASCII	7E1	4800	0 / 1	1	0	0	1	1	0	0	<4C>	<CC>
ASCII	7E1	9600	0 / 1	1	0	0	1	1	0	1	<4D>	<CD>
ASCII	7E1	19200	0 / 1	1	0	0	1	1	1	0	<4E>	<CE>
ASCII	7E1	38400	0 / 1	1	0	0	1	1	1	1	<4F>	<CF>
ASCII	7O1	300	0 / 1	1	0	1	1	0	0	0	<58>	<D8>
ASCII	7O1	600	0 / 1	1	0	1	1	0	0	1	<59>	<D9>
ASCII	7O1	1200	0 / 1	1	0	1	1	0	1	0	<5A>	<DA>
ASCII	7O1	2400	0 / 1	1	0	1	1	0	1	1	<5B>	<DB>
ASCII	7O1	4800	0 / 1	1	0	1	1	1	0	0	<5C>	<DC>
ASCII	7O1	9600	0 / 1	1	0	1	1	1	0	1	<5D>	<DD>
ASCII	7O1	19200	0 / 1	1	0	1	1	1	1	0	<5E>	<DE>
ASCII	7O1	38400	0 / 1	1	0	1	1	1	1	1	<5F>	<DF>
ASCII	8N1	300	0 / 1	1	1	0	0	0	0	0	<60>	<E0>
ASCII	8N1	600	0 / 1	1	1	0	0	0	0	1	<61>	<E1>
ASCII	8N1	1200	0 / 1	1	1	0	0	0	1	0	<62>	<E2>
ASCII	8N1	2400	0 / 1	1	1	0	0	0	1	1	<63>	<E3>
ASCII	8N1	4800	0 / 1	1	1	0	0	1	0	0	<64>	<E4>
ASCII	8N1	9600	0 / 1	1	1	0	0	1	0	1	<65>	<E5>
ASCII	8N1	19200	0 / 1	1	1	0	0	1	1	0	<66>	<E6>
ASCII	8N1	38400	0 / 1	1	1	0	0	1	1	1	<67>	<E7>
ASCII	8E1	300	0 / 1	1	1	0	1	0	0	0	<68>	<E8>
ASCII	8E1	600	0 / 1	1	1	0	1	0	0	1	<69>	<E9>
ASCII	8E1	1200	0 / 1	1	1	0	1	0	1	0	<6A>	<EA>
ASCII	8E1	2400	0 / 1	1	1	0	1	0	1	1	<6B>	<EB>
ASCII	8E1	4800	0 / 1	1	1	0	1	1	0	0	<6C>	<EC>
ASCII	8E1	9600	0 / 1	1	1	0	1	1	0	1	<6D>	<ED>
ASCII	8E1	19200	0 / 1	1	1	0	1	1	1	0	<6E>	<EE>
ASCII	8E1	38400	0 / 1	1	1	0	1	1	1	1	<6F>	<EF>
ASCII	8O1	300	0 / 1	1	1	1	1	0	0	0	<78>	<F8>
ASCII	8O1	600	0 / 1	1	1	1	1	0	0	1	<79>	<F9>
ASCII	8O1	1200	0 / 1	1	1	1	1	0	1	0	<7A>	<FA>
ASCII	8O1	2400	0 / 1	1	1	1	1	0	1	1	<7B>	<FB>
ASCII	8O1	4800	0 / 1	1	1	1	1	1	0	0	<7C>	<FC>
ASCII	8O1	9600	0 / 1	1	1	1	1	1	0	1	<7D>	<FD>
ASCII	8O1	19200	0 / 1	1	1	1	1	1	1	0	<7E>	<FE>
ASCII	8O1	38400	0 / 1	1	1	1	1	1	1	1	<7F>	<FF>

\* When reading register 40026, B7 will be a 0. When writing (changing ITMS communications to the new setting), change B7 to a 1.

This page intentionally left blank

### **LIMITED WARRANTY**

The Company warrants the products it manufactures against defects in materials and workmanship for a period limited to two years from the date of shipment, provided the products have been stored, handled, installed, and used under proper conditions. The Company's liability under this limited warranty shall extend only to the repair or replacement of a defective product, at The Company's option. The Company disclaims all liability for any affirmation, promise or representation with respect to the products.

The customer agrees to hold Red Lion Controls harmless from, defend, and indemnify RLC against damages, claims, and expenses arising out of subsequent sales of RLC products or products containing components manufactured by RLC and based upon personal injuries, deaths, property damage, lost profits, and other matters which Buyer, its employees, or sub-contractors are or may be to any extent liable, including without limitation penalties imposed by the Consumer Product Safety Act (P.L. 92-573) and liability imposed upon any person pursuant to the Magnuson-Moss Warranty Act (P.L. 93-637), as now in effect or as amended hereafter.

No warranties expressed or implied are created with respect to The Company's products except those expressly contained herein. The Customer acknowledges the disclaimers and limitations contained herein and relies on no other warranties or affirmations.

Red Lion Controls  
20 Willow Springs Circle  
York PA 17406  
Tel +1 (717) 767-6511  
Fax +1 (717) 764-0839

Red Lion Controls BV  
Basicweg 11b  
NL - 3821 BR Amersfoort  
Tel +31 (0) 334 723 225  
Fax +31 (0) 334 893 793

Red Lion Controls AP  
31, Kaki Bukit Road 3,  
#06-04/05 TechLink  
Singapore 417818  
Tel +65 6744-6613  
Fax +65 6743-3360