



EA Ultrasonic Level Transmitter

PRODUCT INTRODUCTION

The ultrasonic level transmitter is a non-contact, low-cost and easy-to-install measuring device. The advanced aeronautic technology now is applied to industrial applications with high capability, robustness and applicability on demand. Most important is the ultrasonic level indicator is an easy-to-install device that make the less maintain requirement.

PRINCIPLE

During in operation, the ultrasonic wave firstly emit to the measured medium level. When the ultrasonic wave reaches the surface and reflects back to the transducer, the time interval between transmission and reception will be converted to the physical parameter like the medium level or distance between the ultrasonic level indicator and medium surface. The formula is $D = (334.1 + 0.6t) \times T/2$, where the D = the transmission distance; t = temperature; and T = transmission time.

ZMICROFLEX-C is a compact device which consists of electronic component and transducer. With 4~20mA output, it can be connected to the PLC, DSC and SCADA system. Besides that, it is also equipped with exclusive PULSE and AGC (Auto Gain Control) echo tracking technology to ensure accuracy and precision even in the harsh environment.

FEATURES

- 4~20mA 2 wire output
- 13~30Vdc power supply
- IP67 protection casing
- Compact structure
- Detector material: PVDF
- False echo detection
- Standard 2" Pipe Connection
- Non-contact measurement, easy installation
- Fully isolated analog output
- With internal temperature compensation.
- Beam angle: 6°
- Not affected by liquid characters such as temperature, S.G, viscosity.

MAIN FUNCTIONS

- Level measurement
- Object distance measurement
- Volume measurement
- Differential level measurement
- Pump control

COMPACT STRUCTURE DESIGN

The compact structure design equips with 3 push buttons and operated in 8 parameters mode and LCD display.

USER FRIENDLY OPERATION

It can be configured for level or distance in meters, unit in feet or inch with zero and span calibration at any two points.

RAPID RESPONSE

Conventional loop powered ultrasonic level transmitters are generally slow to respond and hard to detect the rapid moving target. The ZMICROFLEX-C compensates the Doppler's effect internally and makes the difference with other competitor's products; it can detect level moving up to 10 m / min without signal lose. ZMICROFLEX-C is the fastest response of ultrasonic level indicator state-of-the-art.

EXTENSIVE APPLICATIONS

ATEX Hazardous area approved units are available for use in Zone Zero environments. The PVDF transducer is ideal for use in corrosive applications.

FALSE ECHO

Selectable FER function which enables the instrument to identify two fixed obstructions within the path of the ultrasonic beam, memories their position and ignores them during the measuring process.

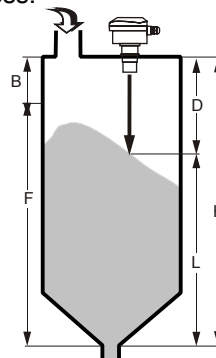

- B = Blanking distance
- D = Distance from transducer to material surface
- L = Height in silo

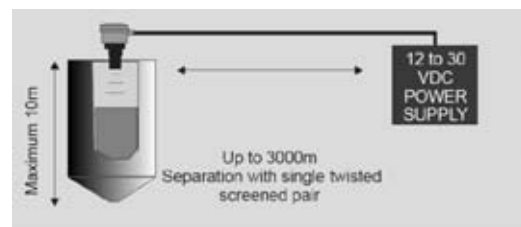

APPLICATIONS

1. Water or waste water treatment equipment: for instance, pump, open channel, dams and wells.
2. Liquid such as edible-oils, sauces, diesel oils and beverages.
3. Chemical material such as solvent, paints, carbonic, water, crude oil, epoxy resin, lime slurry and wax.

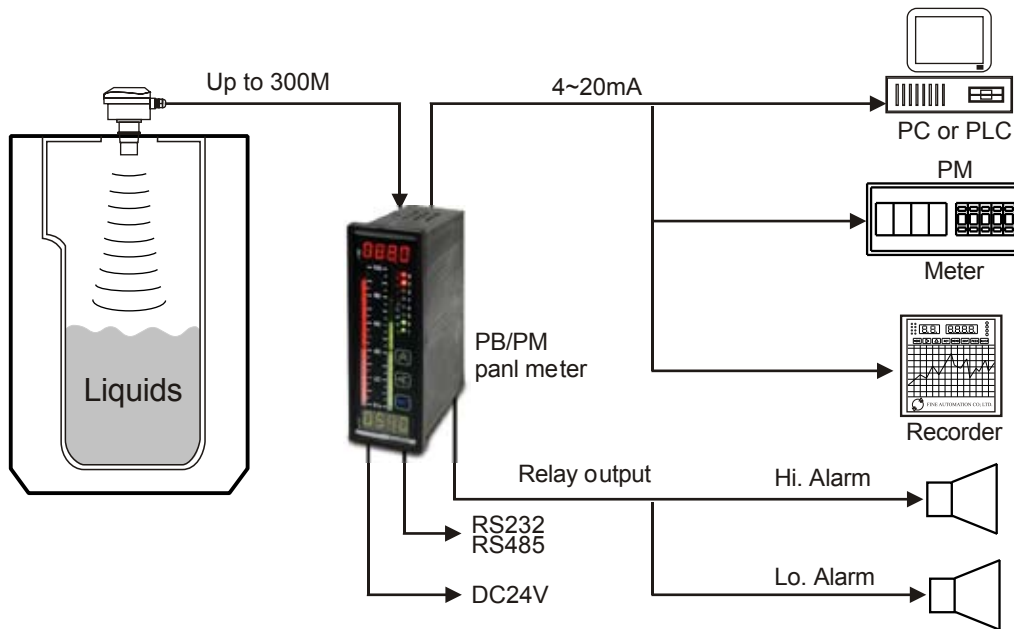

Liquid measurement

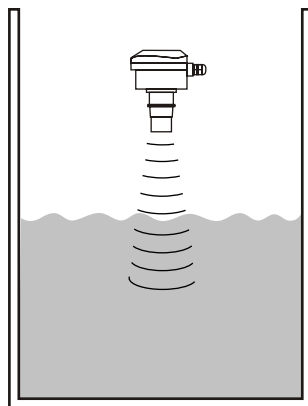

Silo with rotational aiming kit

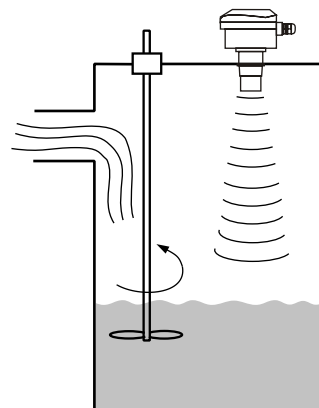

SPECIFICATIONS / DIMENSIONS

| Type | ZMICROFLEX-C | ZMICROFLEX-CER | ZMICROFLEX-CIS |
|--------------------------------------|--------------------------------|--|--|
| Specifications | | | |
| Measuring Range | 8M(0.3~8M) | 10M(0.45~11M) | 10M(0.45~11M) |
| Accuracy | <1.0m ± 5mm. >1.0m ± 0.5%* | <1.0m ± 2.5mm. >1.0m/3.3ft ± 0.25%* | <1.0m ± 2.5mm. >1.0m/3.3ft ± 0.25%* |
| Resolution | 1mm | 1mm | 1mm |
| Dead Band | 300mm | 450mm | 300mm |
| Ambient temperature | -20°C~70°C | -40°C~60°C | -40°C~60°C |
| Operating temperature | -20°C~70°C | -30°C~70°C | -30°C~70°C |
| Operating pressure | -0.25~3Bar | -0.25~3Bar | -0.25~3Bar |
| Power supply | 2 wire 12~30Vdc | 2 wire 12~30Vdc | 2 wire 12~30Vdc |
| Analog output | 4~20mA(750 Ohm) | 4~20mA(750 Ohm) | 4~20mA(750 Ohm) |
| Relay output | None | 2XSPST/1A 24V DC | None |
| Communication Protocol | None | HART | HART |
| Display | 4 digital 12mm LCD | 4 digital 12mm LCD | 4 digital 12mm LCD |
| Electrical entry | 2XM20X1.5 | 2XM20X1.5 | 2XM20X1.5 |
| Transducer material | PVDF | PVDF | PVDF |
| Beam Angle | ±6°(3dB) | ±6°(3dB) | ±6°(3dB) |
| Casing material | Nylon | Nylon | Nylon |
| Process connection | 2" BSPT/NPT | 2" BSPT/NPT | 2" BSPT/NPT |
| Protection rating | IP67 | IP67 | IP67 |
| Electromagnetic compatibility | CE EN 50081-1 CE EN 50082-2 | CE EN 50081-1 CE EN 50082-2 | CE EN 50081-1 CE EN 50082-2 |
| Explosion rating | None | None | EEx ia II CT4~T6 |
| Weight | 850g | 1200g | 1200g |

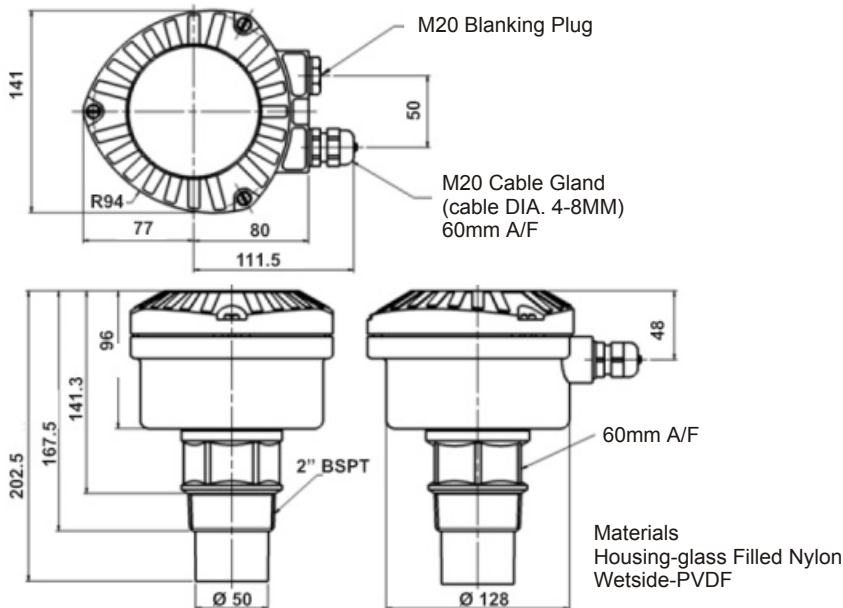

INSTALLATION

2-wires (Power Supplied by panel meter)

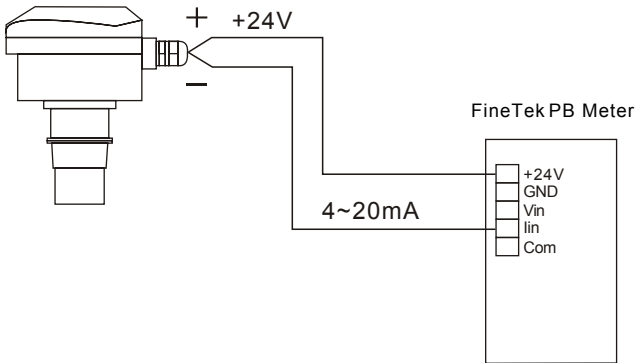

The ultrasonic transducer is mounted to the flange of the extension neck of the tank. Please refer to the instruction below:

Length for dead band:
 Dead band has to be 150mm over extension neck.
 Dead band needs to be set as 500mm if extension neck is shorter than 500mm.

Extension length:
 Please refer to below table and choose the suitable fixed probe

| Flange size | Diameter of extension probe(ϕ)Min | Diameter of extension probe L (Max) |
|-------------|--|-------------------------------------|
| 3" | 75mm | 300mm |
| 4" | 100mm | 300mm |
| 6" | 150mm | 400mm |
| 8" | 200mm | 600mm |
| 12" | 300mm | 600mm |

2-wires Power Supply (External)

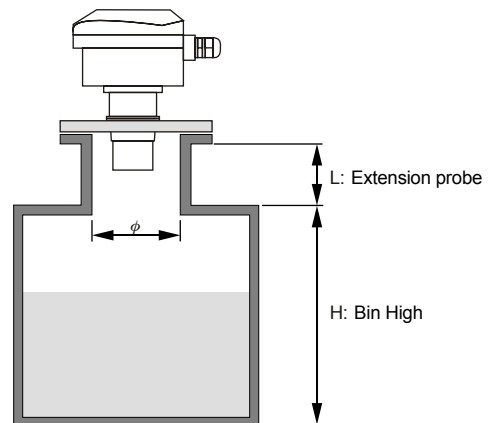
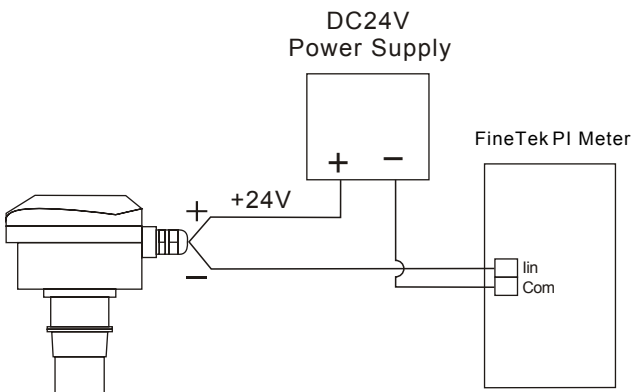

4-wire (PLC)

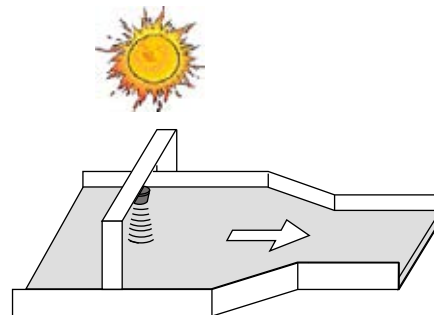
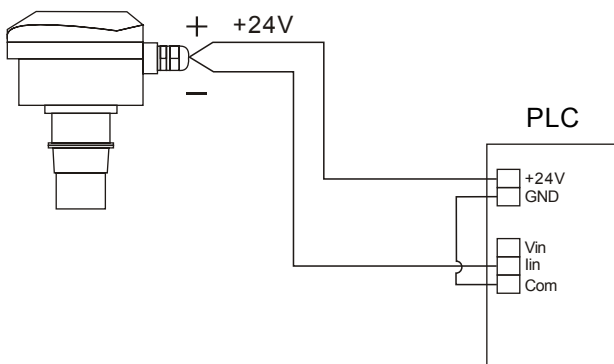

Keep the transducer away from sunshine

SET UP PROCEDURE

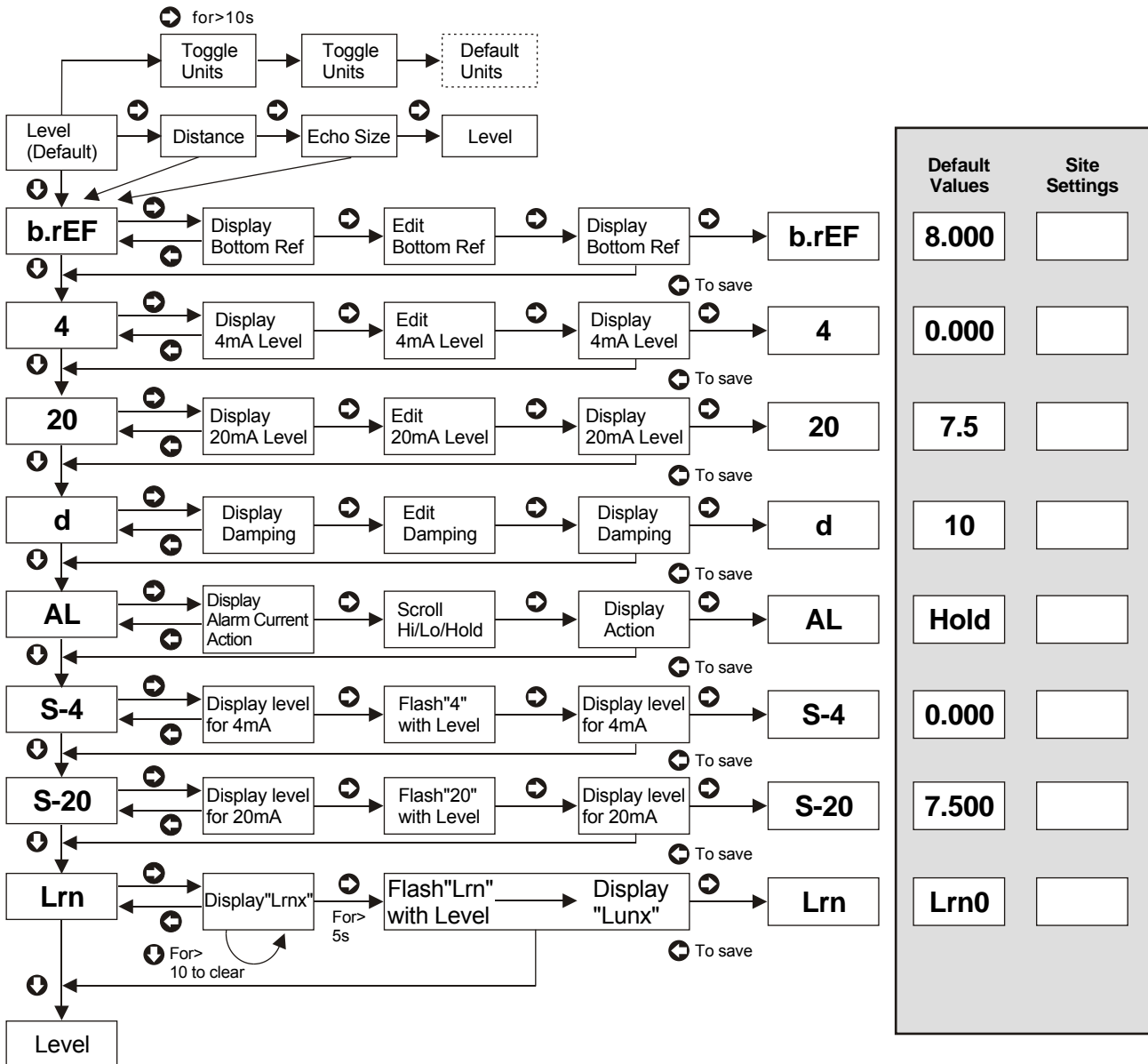

Parameter Function Statement

| Item | Parameter | Function Statement |
|------|-----------|--|
| 1 | Level | Set the showing value corresponds to the level or distance |
| 2 | b.rEF | Set the bin high |
| 3 | 4 | Set the showing value on 4~20mA (solid, distance, volume...) |
| 4 | 20 | Set the showing value on 20mA (solid, distance, volume...) |
| 5 | D | Set damping time (When the value is getting big which means that the number is more stable but the responding time becomes slow) |
| 6 | AL | Set the alarming current (when it is abnormal, the output current can set as 22mA /maintenance/3.5mA) |
| 7 | S-4 | Set the low point at 4mA (general is low level) |
| 8 | S-20 | Set the height point at 20mA (general is high level) |
| 9 | Lrn | Exclude the obstacles(excluding the false signal reflected from obstacles) |

CAUTION BEFORE INSTALLATION

Keep the transducer perpendicular to the liquid surface.

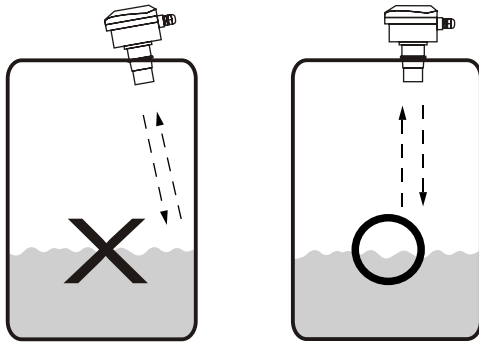

The transducer should not be mounted too close to the tank wall to avoid interference caused by the tank wall.

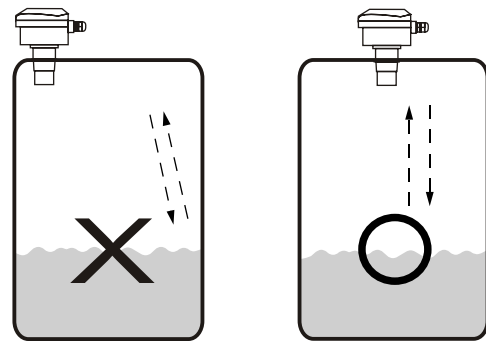

A pipe surrounding the detection path along the ultrasonic wave from emitting to receiving is recommended, thus installation can prevent fake signal caused by turbulence and foam when agitator is equipped in the tank. When the pipe is installed, a vent hole is required to balance the pressure difference between the inside and outside of pipe.

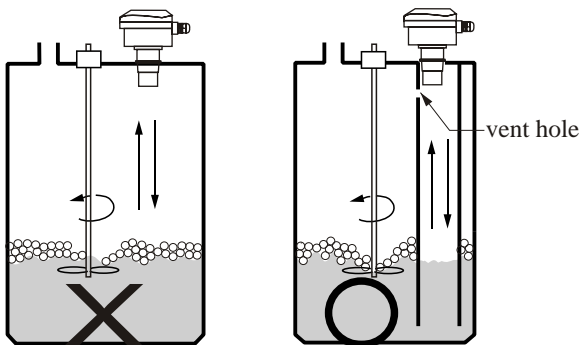

Do not mount the device close to the tank wall in case the fake signal caused by the bracket.

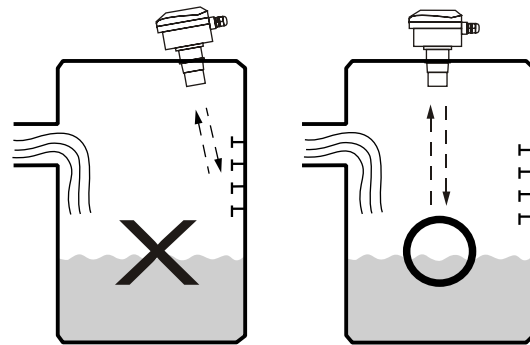

Mount the transducer away from the inlet to avoid interfere by medium.

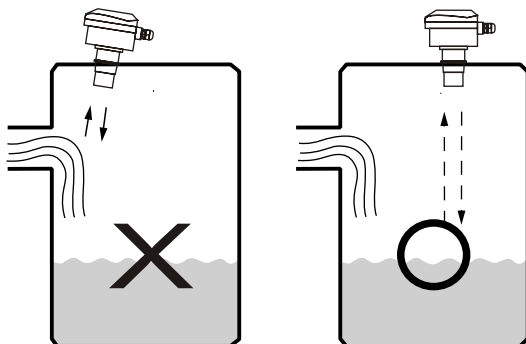

When user mount the transducer on the solid tank, the transducer must point to the outlet of tank.

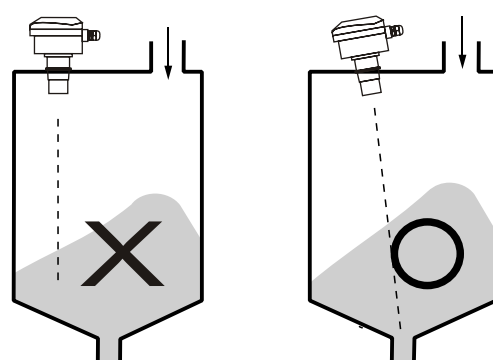

EXAMPLES-OF-TANK-MOUNTING

- [FC/FD] Mini Float/Magnetic Float Level Switch
- [FG] Magnetic Float Level Transmitter
- [FF] Side Mounting Float Switch
- [FA/FB] Cable Float Level Switch
- [SP] Thermal Dispersion Flow Switch
- [SF] Paddle Flow Switch
- [SD] Optical Level Switch
- [SE] Rotary Paddle Level Switch
- [SA] Capacitance Level Switch
- [EC] Pressure Level Transmitter
- [LR] Loop Power Indicator
- [SC] Vibrating Probe Level Switch
- [SC] Tuning Fork Level Switch
- [EB] RF-Capacitance Level Transmitter
- [SB] RF-Capacitance / Admittance Level Switch
- [EG] Magnetostrictive Level Transmitter
- [EF] By-Pass Level Transmitter
- [MEF] Mini By-Pass Level Transmitter
- [EA] Ultrasonic Level Transmitter
- [JFR] FMCW Radar Level Transmitter
- [EE] Electromechanical Level Measuring System
- [ED] Speed Monitor
- [SRT/SRS] Conveyer Belt Misalignment Switch & Safety Cable Pull Switch
- [PB/PM] Microprocessor Based Bargraphic Display Scaling Meter
- [BRD/AE] Valve and Controller for Dust Collector System
- [BAS/BAH/BVP] Air Hammer
- [BVK/BVR/BVT] Pneumatic Vibrator

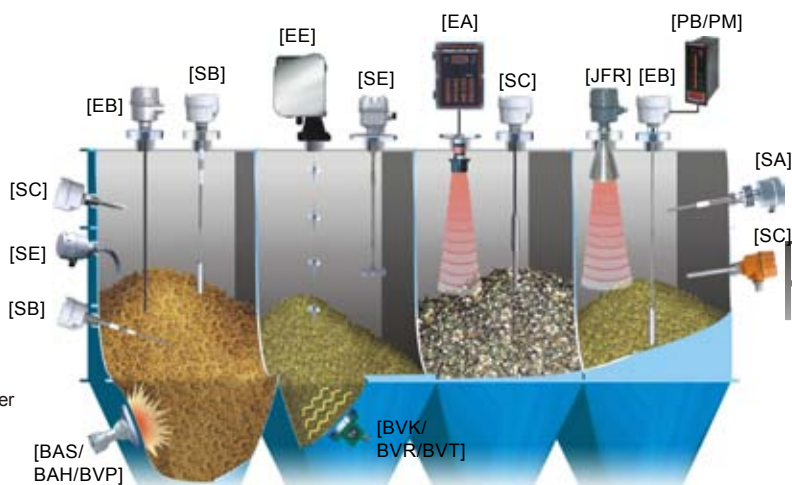
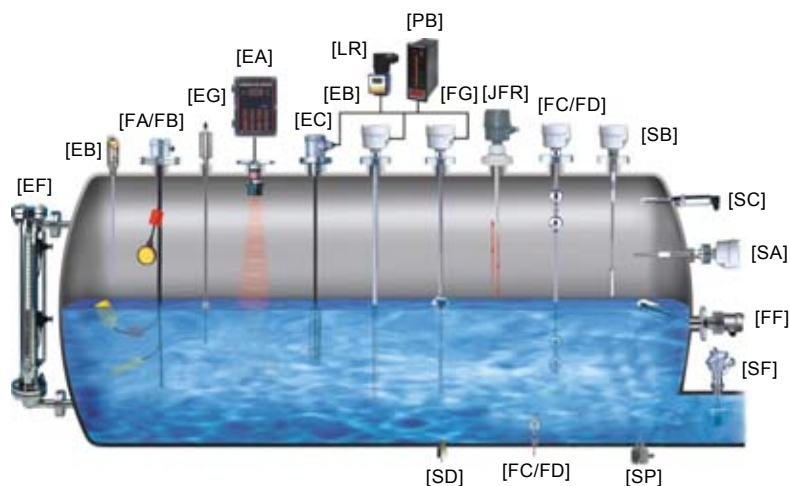

FineTek Co., Ltd.

No.16, Tzuchiang St., Tucheng Industrial Park, New Taipei City 236, Taiwan
 TEL: +886-2-2269-6789 FAX: +886-2-2268-6682
 Email: info@fine-tek.com

Fine automation (ShangHai) Co., Ltd.

No.451 DuHui Rd, MinHang District, Shanghai, China 201109
 TEL: +86-21-6490-7260 FAX: +86-21-6490-7276
 Email: info.sh@fine-tek.com

FineTek Pte Ltd.

No. 11 Kaki Bukit Road 1, #04-01 Eunos
 Technolink 415939, Singapore
 TEL: +65-6452-6340 FAX: +65-6734-1878
 Email: info.sg@fine-tek.com

FineTeK GmbH

Frankfurter Str. 62, OG D-65428 Ruesselsehim, Germany
 TEL: +49-(0)6142-17608-0 FAX: +49-(0)6142-17608-20
 E-Mail: info@fine-tek.de



Distributor:



Garma Electrónica, S.L.
 CIF. B-20178372
 CALLE OYARZUN, 1 bajo
 20013 SAN SEBASTIAN
 Tel. 943 29 11 02 · fax 943 27 35 77
 www.garmasl.com · garma@garmasl.com